



Before using this **EZG MIXER®**,
study and understand entire
Owner's Manual.

Serial Number _____

EZG9 MIXER®

9ft³ (0.25m³)



Mixing Station

Owner's Manual



EZG7 MIXER®
EZG Manufacturing
1-800-417-9272

EZG Manufacturing
405 Watertown Road
Waterford, Ohio 45786
(740) 749-3512 or 1-800-417-9272
Fax (740) 962-2037 www.ezgrout.com

Table Of Contents

Introduction.....	1
About this Manual.....	1
General Information.....	1
Safety Information.....	1
Safety Precautions.....	2
California - Proposition 65 Warning.....	3
Setup Instructions.....	4
Operating Instructions.....	4
Daily Maintenance.....	4
Obtaining Spare Parts.....	5
Clean Up.....	5
Warning Labels and Locations.....	6
Frame Assembly.....	7
Shaft Assembly.....	8
Grease Fitting Location.....	9
Optional Electric Motor Specifications.....	9
Wheel Hub Assembly.....	10
NotesWarranty.....	10
Warranty Registration.....	12

Introduction

Congratulations on purchasing one of the finest pieces of masonry equipment on the market today! If this is your first EZG Manufacturing product, you will not be disappointed. If you have previously owned an EZG Manufacturing product you will find the same high quality and dependability that you have come to expect from EZG Manufacturing.

About this Manual

The purpose of this manual is to inform the owner, employer, and the operator's of the unit, how to safely operate this piece of equipment, and make them aware of any hazards. It also contains important information regarding assembly, set up, operation, and maintenance. It is the Owner/Employer's responsibility to make sure that anyone who operates this machine understands all safety warnings. If you do not understand any items in this manual, please contact the dealer where this product was purchased, or the manufacturer at the number listed throughout the manual. If you have any suggestions about how to make this manual easier to understand, contact the manufacturer. Keep this manual available for reference wherever this piece of equipment is being used and make it available to any operators.

General Information

Illustrations in this manual may show details or components that may not be the same as your machine. Continuing improvements to the design of this machine may have caused changes that are not reflected in this manual. The information in this document is subject to change without notice.

Safety Information

The following safety symbols and signal words will be used throughout this manual and on the product, for your safety and the safety of others, please become familiar with their meaning and heed their warnings.



This symbol, either used alone or with a signal word, is used to call your attention to instructions involving your safety and/or the safety of others. Failure to follow these instructions could result in personal injury or death.



DANGER

This signal word is used to identify a hazard which, if not avoided, will result in death or serious injury.



WARNING

This signal word is used to identify a hazard which, if not avoided, could result in death or serious injury.



CAUTION

This signal word is used to identify a hazard which, if not avoided, could result in minor or moderate injury.

NOTICE

This signal word is used to identify a hazard which, if not avoided, could result in property or equipment damage. It also may be used for special instructions related to performance, maintenance or general items.

Safety Precautions

NOTICE

In this manual, **EZG9 MIXER**[®] is commonly referred as “unit”, “mixer”, or “mixing station”..



WARNING

Failure to obey the following safety instructions could result in DEATH or SERIOUS INJURY.

Read and understand entire manual before operating any EZG Manufacturing product.

For your safety and the safety of others, replace any missing or damaged warning decals by contacting the manufacturer at 1-800-417-9272.

Make sure anyone operating the mixer is thoroughly familiar with its operation. Keep all unauthorized and untrained personnel, especially children, away from the unit.

Never operate the unit with safety grate, guards or safety devices removed or open. Do not alter any safety guards.

Stay clear of mixing paddles while the unit is running. Keep all body parts, clothing, jewelry and solid objects away from moving parts.

Never perform any work on the mixer while it is running. Before working on or cleaning the unit, shut off engine and disconnect spark plug wire.

Never operate the mixer under the influence of alcohol, drugs, or medications.

This **EZG9 MIXER**[®] has been designed and built as a material mixing station, and should not be used for anything other than its intended purpose.

If used, consult forklift manufacturers specifications to insure load capacity is not exceeded.

Never stand under an elevated mixer.

Stay clear of moving parts while the unit is in operation.

Model	Empty Weight	Max Gross Weight
EZG9	895 lbs. (405.9 kg)	2195 lbs. (995.6 kg)

Do not exceed Maximum Gross Weight

When towing, refer to vehicle manufacturer’s specifications to insure load capacity is not exceeded.

Always check axle, tires, and safety chains before towing the unit.

Always cross and connect safety chains before towing the unit.

Never attempt to ride the mixer.

Operate only in properly vented environments. The mixer requires a free flow of air and emits carbon monoxide gas.

Avoid breathing dust produced while using the unit. Dust may contain crystalline silica and may cause serious health problems.

Do not operate near combustible materials.

Do not smoke around the mixer.

Safety Precautions (cont.)

Always know the location of nearest fire extinguisher, first aid kit, and emergency personnel phone numbers in case of emergency.



CAUTION

Failure to obey the following safety instructions could result in MINOR or MODERATE INJURY.

Inspect all fasteners, bolts and welds for nicks, cracks, cuts, damage, wear or looseness before each use. Repair as needed.

Always wear approved PPE, including glasses, hearing protection, hard hats, and ventilation masks when operating the mixer.

Do not use the mixer as a lifting device or with accessories or attachments not recommended by EZG Manufacturing, as damage to equipment or injury to operator may occur.

Allow system to cool before performing any repairs or service, such as adding fuel or oil.

NOTICE

Use only factory authorized parts.

Used lubricants such as engine oil and hazardous waste must be taken to an authorized disposal or recycling center.

Consult Honda® Owners Manual for engine maintenance and warnings.

California - Proposition 65 Warning

Engine exhaust and some of its constituents, and some dust created by power sanding, sawing, grinding, drilling, and other construction activities contains chemicals known to the State of California to cause cancer, birth defects and other reproductive harm. Some examples of these chemicals are:

Lead from lead based paints - Crystalline silica from bricks - Cement and other masonry products - Arsenic and chromium from chemically treated lumber.

Your risk from these exposures varies, depending on how often you do this type of work. To reduce your exposure to these chemicals: ALWAYS work in a well ventilated area, and work with approved safety equipment, such as dust masks that are specially designed to filter out microscopic particles.

Setup Instructions

Before operating the **EZG9 MIXER**[®] it should be properly set up on the job site (the unit may be lifted by using a forklift). The EZG9 weighs 895 lbs. (405.9 kg) empty and 2195 lbs. (995.6 kg) full. Check forklift ratings before attempting to move the unit.

The unit is equipped with (2) wheels and a tow tongue.

1. Position the unit at point of operation.
2. Disconnect unit from towing vehicle.
3. Lower tongue until mixer is level.
4. Verify that the mixer foot is touching the ground and that the unit is level and cannot rock in any direction.
5. Perform the daily maintenance as described in the “Daily Maintenance” section of this manual.

Operating Instructions



WARNING

This equipment is to be operated by trained and qualified personnel over the age of 18. Death or serious injury can result.

1. Slide forks under the unit and place in desired location.
2. Level unit and chock wheels.



WARNING

NEVER put your hands inside mixer drum while equipment is running. Death or serious injury can result.

3. Start engine.
See engine manuals for proper procedure.
4. Fill mixer with material, add water and mix to desired consistency and dump.
NOTE: In the unlikely event that the mixing paddles plug, momentarily reverse the paddles.

Daily Maintenance



WARNING

Before performing any described maintenance items, make sure engine is turned off and spark plug wire is disconnected. Death or serious injury can result.

1. Check engine oil daily.
2. For engine maintenance, refer to the engine manufacturer’s manual furnished with the unit.
3. Check and lubricate all grease fittings.
See page 10 for grease fitting locations.
4. For maximum performance, thoroughly clean inside and out at mid-day or lunch break and again at the end of each day’s use. Do not allow a buildup of material to form on the blades and seals.
5. Check equipment for leaks. Fix any leaks before operating the unit.
6. Check all welds. If a cracked weld is found, do not operate the mixer until repaired by qualified personnel.
7. Check all bolts. Tighten any loose bolts.
8. Check Paddle Shaft Seal for excessive wear. If any mortar or concrete is leaking past the seal, change the seals immediately.
9. Check paddle rubber for wear. Adjust or replace as needed.

Warning Labels and Locations

1 **WARNING**
CRUSH HAZARD!
Never open grate with motor running.
Rotating paddles can cut and crush.

3 **WARNING**
PINCH HAZARD!
Stay clear of moving parts on the machine in operation.
Failure to follow operating instructions could result in death or serious injury.

6 **WARNING**
Do not remove while mixer is running.

10 **U.S. FLAG**
MANUFACTURED WITH PRIDE IN MORISGAN COUNTY, OHIO, USA.

5 **NOTICE**
Grease seals daily. Use EPI rated or equivalent grease.

3 **WARNING**
PINCH HAZARD!
Stay clear of moving parts on the machine in operation.
Failure to follow operating instructions could result in death or serious injury.

11 **WARNING**
To comply with DOT regulations, chains must be crossed when in tow.

8 **RECOMMENDED OIL**
Fill with 1.1 quarts of 15w-40 with an API rating of SJ, SI or equivalent.

14 **SERIAL TAG LOCATION**

13 **NOTICE**
ENGAGE PADDLES/ DISENGAGE PADDLES

12 **WARNING**
HOT SURFACE
Do not touch.
Burns may result.

4 **WARNING**
BURN HAZARD!
Surface may be hot.
Do not touch.
Burns may result.

7 **NOTICE**
California Public Resources Code 4462.3 requires any internal combustion engine operated near forest-covered, brush-covered, or grass-covered land to be equipped with an exhaust spark arrester.

9 **WARNING**
Before using this equipment, read and understand entire operator's manual.
Failure to follow operating instructions could result in death or serious injury.

15 **ATTENTION**
INSPECT BEFORE TOWING
TOY TRAILER OR TRAILER
1. USE MANUFACTURER'S RECOMMENDED TORQUE VALUES WHEN TIGHTENING WHEEL LOCK NUTS.
2. USE MANUFACTURER'S RECOMMENDED TORQUE VALUES WHEN TIGHTENING TIES. DO NOT EXCEED RECOMMENDED TORQUE.

16 **WARNING**
STAND CLEAR OF DUMP HANDLE. HANDLE KICK-BACK IS POSSIBLE.

ITEM	PART NUMBER	DESCRIPTION	QTY
1	16-159	Never Open Grate - Decal	1
2		Not Used	2
3	16-131	Pinch Point - Decal	2
4	16-112	Hot Surface - Decal	2
5	16-125	Grease Seals Daily - Decal	2
6	16-165	Do Not Remove - Decal	1
7	16-149	California Public Resources - Decal	1
8	16-156	Recommended Oil - Decal	1
9	16-177	Read Owners Manual - Decal	1
10	16-106	U.S. Flag - Decal	1
11	16-179	DOT Cross Chains - Decal	1
12	16-193	Proposition 65 - Decal	1
13		Engage/Disengage Paddles - Decal	1
14		Serial Tag Location	1
15		Inspect Before Towing - Decal	1
16		Stand Clear of Handle - Decal	1

Frame Assembly

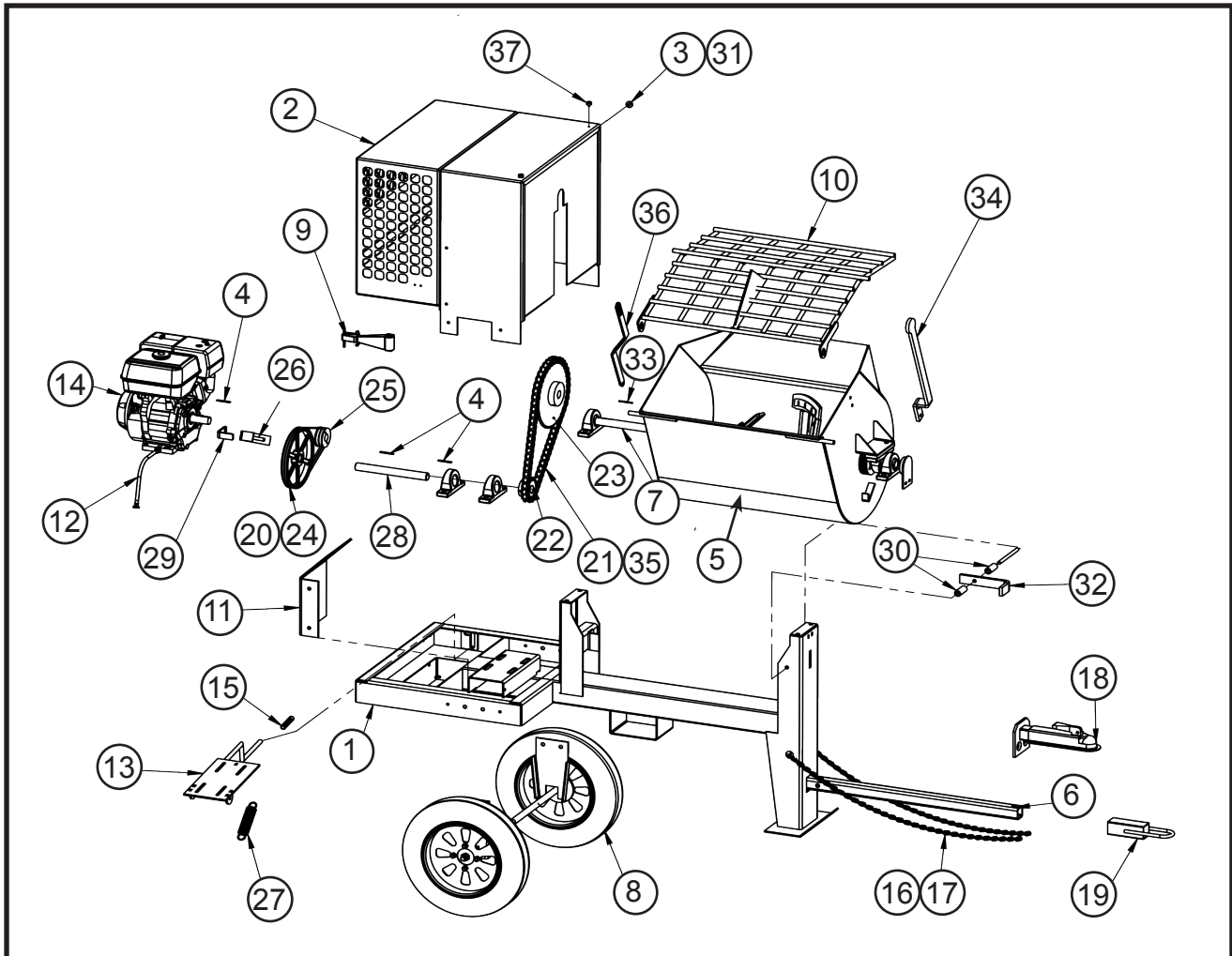

ITEM	PART NUMBER	QTY	DESCRIPTION
1	EZG9-A-1	1	EZG9 MIXER FRAME
2	EZG9-A-2	1	HOOD
3	03-104	1	EMERG. STOP BUTTON
4	EZG-503	3	1/4" SHAFT KEY
5	EZG9-A-3	1	DRUM
6	EZG-500	1	TONGUE
7	EZG9-A-4	1	PADDLE SHAFT ASSEMBLY
8	EZG-A-2	1	AXLE
9	20-103	2	HOOD HOLD DOWN
10	EZG9-A-6	1	GRATING
11	EZG-4	1	PULLEY GUARD
12	20-120	1	ENGINE DRAIN HOSE-DRAINZIT
13	EZG-A-3	1	HONDA ENGINE MOUNT PLATE
14	14-108	1	7.8 HP HONDA ENGINE
15	20-158	1	ENGAGE-HANDLE GRIP
16	09-700	1	SAFETY CHAIN
17	09-701	2	SAFETY CHAIN CLIP
18	EZG-2	1	2" BALL TONGUE
19	EZG-3		DRAWBAR TONGUE (PINTLE)

ITEM	PART NUMBER	QTY	DESCRIPTION
20	15-112	2	BELT
21	EZG9-A-5	1	DRIVE CHAIN 66"
22	15-110	1	SMALL SPROCKET
23	15-111	1	LARGE SPROCKET
24	15-128	1	LARGE PULLEY 1-1/4"
25	15-127	1	SMALL PULLEY 1"
26	EZG-5	1	BELT TENSIONER LG
27	09-808	1	SPRING
28	EZG-A-4	1	PULLEY DRIVE SHAFT
29	EZG-6	1	BELT TENSIONER SM
30	EZG-504	2	SPACER
31	EZG-A-1	1	E-STOP WIRING HARNESS
32	EZG-7	2	DRUM RELEASE
33	EZG-502	1	3/8" SHAFT KEY
34	EZG-8	1	DRUM HANDLE
35	15-130	1	CHAIN MASTER LINK
36	EZG9-1	1	GRATE OPENER
37		2	HOOD STOP

Shaft Assembly

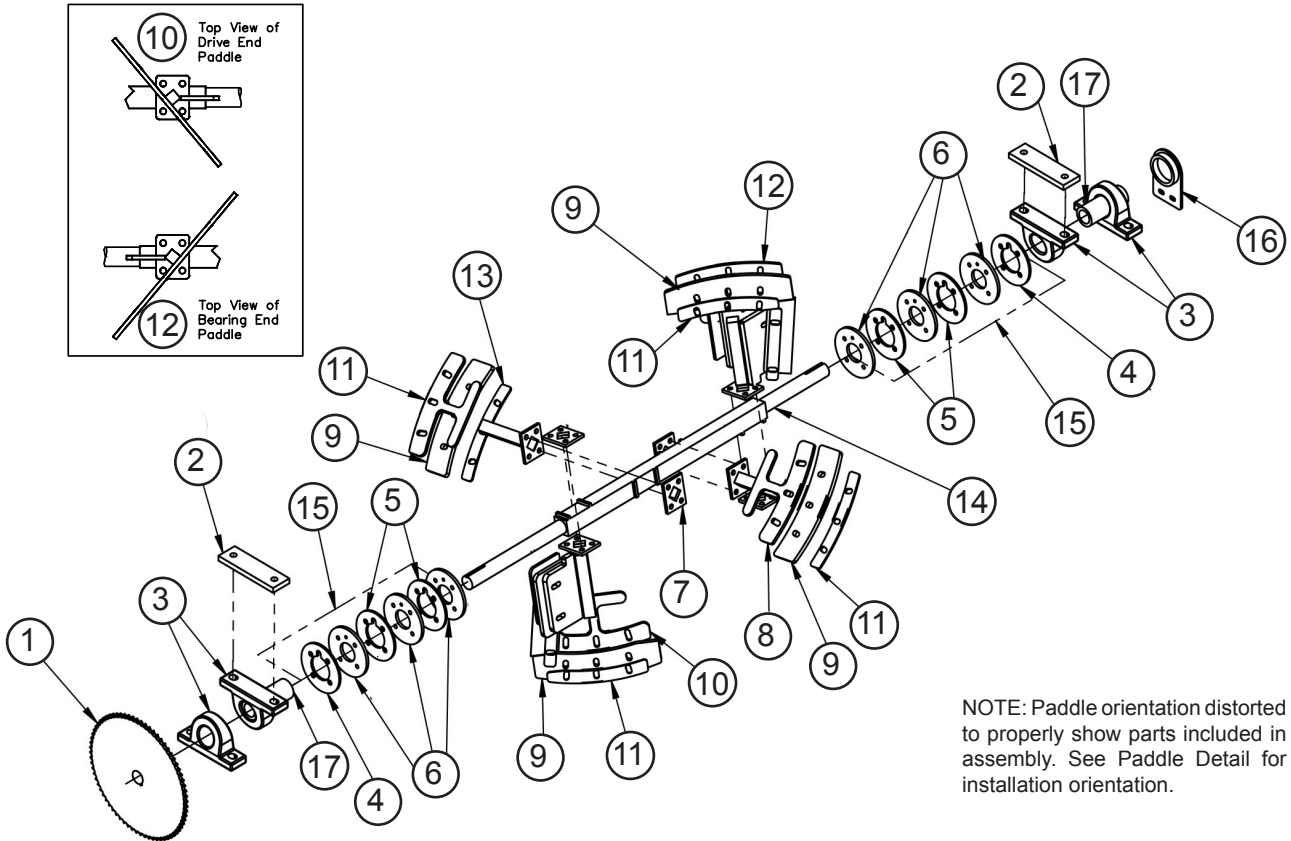

NOTE: Paddle orientation distorted to properly show parts included in assembly. See Paddle Detail for installation orientation.

ITEM	PART NUMBER	QTY	DESCRIPTION
1	15-111	1	LARGE SPROCKET
2	EZG-1	2	BEARING SPACER
3	15-109	4	1-1/4" PILLOW BLOCK BEARING
4	GH-18	2	OUTER SEAL PLATE
5	GH-17	4	INNER SEAL PLATE
6	13-116	6	PADDLE SHAFT SEALS
7	EZG9-3	4	PADDLE MOUNTS
8	EZG9-A-11	1	BEARING END CENTER PADDLE
9	EZG9-A-13	1	PADDLE RUBBER KIT WITH BOLTS (NO COVER)
10	EZG9-A-9	1	DRIVE END OUTER PADDLE
11	EZG9-A-14	1	PADDLE COVER KIT (NO RUBBER, BOLTS)
12	EZG9-A-12	1	BEARING END OUTER PADDLE

ITEM	PART NUMBER	QTY	DESCRIPTION
13	EZG9-A-10	1	DRIVE END CENTER PADDLE
14	EZG9-A-4	1	SHAFT
15	EZG9-A-17	2	SHAFT SEAL KIT (INCLUDES (6)13-116, (4) GH-17, (2) GH-18)
	EZG9-A-15	1	PADDLE KIT (INCLUDES (1) EZG9-A-9, (1) EZG9-A-10, (1) EZG9-A-11, (1) EZG9-A-12, (1) EZG9-A-13, (1) EZG9-A-14, (4) EZG9-3)
	EZG9-A-16	1	PADDLE BOLT KIT
16	EZG-A-5	1	SHAFT BEARING GUARD
17	EZG-505	2	SHAFT COLLAR

Grease Fitting Location

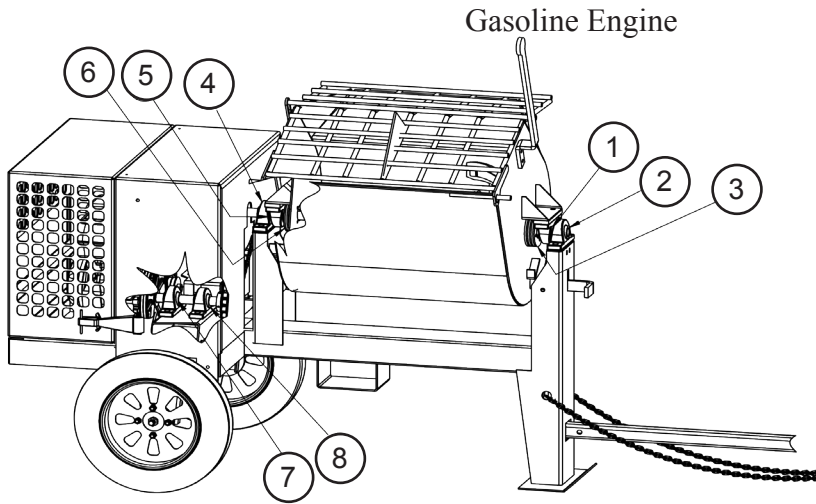

Electric Motor - Additional Lubrication Points

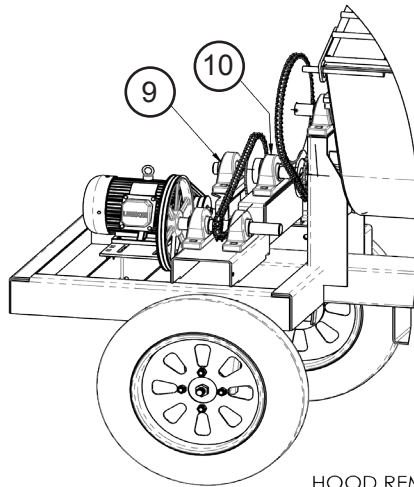

ITEM	DESCRIPTION
1	BEARING
2	BEARING
3	SHAFT SEAL
4	BEARING
5	BEARING
6	SHAFT SEAL
7	BEARING
8	BEARING
9	BEARING
10	BEARING

NOTE: Check ALL grease fitting location daily. Grease as needed.

Optional Electric Motor Specifications

CLOCKWISE ROTATION FROM BACK OF MOTOR

Model	VOLTAGE	HP	FLA	FRAME	RPM
Leeson	115v 60hz	2.0	18.4	145	1800

Warranty

Limited Warranty

The manufacturer warrants that products manufactured shall be free from defects in material and workmanship that develop under normal use for a period of one year on all products from the date of shipment. The foregoing shall be the exclusive remedy of the buyer and the exclusive liability of the manufacturer. Our warranty excludes normal replaceable wear items, i.e. gaskets, wear parts, seals, O-rings, belts, drive chains, clutches, etc. Any equipment, part or product which is furnished by the manufacturer but manufactured by another, bears only the warranty given by such other manufacturer. (Manufacturer agrees to furnish free of charge a written description of problem or cause.) Warranty is voided by product abuse, alterations, use of equipment in applications for which it was not intended, use of non-manufacturer parts, or failure to follow documented service instructions. The foregoing warranty is exclusive of all other warranties whether written or oral, expressed or implied. No warranty of merchantability or fitness for a particular purpose shall apply. The agents, dealers, and employees of Manufacturer are not authorized to make modifications to this warranty, or additional warranties binding on the Manufacturer. Therefore, additional statements, whether oral or written, do not constitute warranty and should not be relied upon.

The Manufacturer's sole responsibility for any breach of the foregoing warranty provisions, with respect to any product or part not conforming to the Warranty or the description herein contained, is at its option (a) to repair, replace, or refund such product or parts upon the prepaid return thereof to location designated specifically by the Manufacturer. Product returns not shipped prepaid will be refused (b) as an alternative to the foregoing modes of settlement the Manufacturer's dealer may repair defective units with reimbursement for expenses. A written description of problem or cause must accompany all warranty claims.

Except as set forth here in above and without limitation of the above, there are no warranties or other affirmation which extend beyond the description of the products on the fact here of, or as to operational efficiency, product reliability, or maintainability or compatibility with products furnished by others. In no event, whether as a result of breach of contract or warranty or alleged negligence, shall the Manufacturer, be liable for special or consequential damages including but not limited to: Loss of profits or revenue, loss of use of the product or any associated product, cost of capital, cost of substitute products, facilities or services or claims of customers. Manufacturer does not assume responsibility for any accident due to equipment modification.

No claim will be allowed for products lost or damaged in transit. Such claims should be filed with the carrier within fifteen days.

Effective July 20, 2005

EZG Manufacturing is the exclusive manufacturer of the patented **Grout Hog**[®] Grout Delivery System the **Mud Hog**[®] Hydraulic Mixing Station, the **Hog Trough**[®] mud pan, the **Hog Cart**[™], the **Hog Slopper**[™], the **Booger Hog**[®] Wall Scrubber, the **Hog Leg**[®] Wall Brace System, the **Hog Crusher**[™] Material Recycling System, and the **EZG MIXER**[®].

Fax Warranty Registration form to 740-962-2037
Submit on-line at www.ezgrout.com/warranty
or click on "Products" then "Warranty Cards".

Warranty Registration

Contact: _____

Company Name: _____

Address: _____

City: _____ State: _____ Zip: _____

Phone: _____ Fax: _____ Email: _____

Purchased From: _____

Purchased Date: _____ Serial No.: _____

Please complete this warranty card, and return via mail, fax or email, within 30 days of purchase to validate your manufacturer's warranty for all EZG Manufacturing products.

Warranty provisions of this machine are handled directly through the manufacturer.

EZG Manufacturing * 405 Watertown Road, Waterford, OH 45786 *

Fax: 740-962-2037 * Email: warranty@ezgrout.com

Please take a minute to fill out the survey below so that we can better serve our customers.

EZ Survey

1. Where did you first hear about EZG Manufacturing? (Check One)

Masonry Magazine Website Newsletter Referral Masonry Construction

Other: _____

2. What influenced you to buy? Quality Price Easy to use Other

3. Who is your Sales Representative? _____

4. Are you satisfied with the customer service you received? Yes No

Explain: _____

5. What other EZG Manufacturing products do you own? _____

6. Would you like to be featured in our Newsletter? Yes No

If yes, where can we reach you and what is the best time? _____

Comments: _____
