



Before using this Barbed Wire Hog®, study and understand entire Owner's Manual.

Serial Number \_\_\_\_\_



# **Barbed Wire Hog®**

## **Owner's Manual**



**Barbed Wire Hog®**

**EZG Manufacturing  
1-800-417-9272**

**EZG Manufacturing  
405 Watertown Road  
Waterford, Ohio 45786  
(740) 749-3512 or 1-800-417-9272  
Fax (740) 962-2037 [www.ezgmfg.com](http://www.ezgmfg.com)**

# TABLE OF CONTENTS

INTRODUCTION.....	3
ABOUT THIS MANUAL.....	3
GENERAL INFORMATION.....	3
SAFETY INFORMATION.....	3
SAFETY PRECAUTIONS.....	4-5
CALIFORNIA PROPOSITION 65 WARNING.....	5
SETUP INSTRUCTIONS.....	6
LOADING BARBED WIRE.....	6-7
OPERATING INSTRUCTIONS.....	7
DAILY MAINTENANCE.....	8
OBTAINING SPARE PARTS.....	8
SERVICE RECORDS.....	8
PIVOT ARM LOCATIONS.....	9
FRAME ASSEMBLY.....	10
UPPER ARM ASSEMBLY.....	11
TOP TENSION WIRE ATTACHMENT INSTALLATION.....	12
TOP TENSION WIRE ATTACHMENT ASSEMBLY.....	13
BOTTOM TENSION WIRE ATTACHMENT INSTALLATION.....	14
BOTTOM TENSION WIRE ATTACHMENT ASSEMBLY.....	15
WARNING LABELS AND LOCATIONS.....	16
NOTES.....	17
WARRANTY.....	18
WARRANTY REGISTRATION.....	19

# INTRODUCTION

Congratulations on purchasing one of the finest pieces of fencing equipment on the market today! If this is your first EZG Manufacturing product, you will not be disappointed. If you have previously owned an EZG Manufacturing product you will find the same high quality and dependability that you have come to expect from EZG Manufacturing.

## ABOUT THIS MANUAL

The purpose of this manual is to inform the owner/employer/and the operator, how to safely operate this piece of equipment, and make them aware of any hazards. It also contains important information regarding assembly, set up, operation, and maintenance. It is the Owner/Employers responsibility to make sure that anyone who operates this machine understands all safety warnings. If you do not understand any items in this manual, please contact the dealer where this product was purchased, or the manufacturer at the number listed throughout this manual. If you have any suggestions about how to make this manual easier to understand, contact the manufacturer. Keep this manual available for reference wherever this piece of equipment is being used and make it available to any operators.

## GENERAL INFORMATION

Illustrations in this manual may show details or components that may not be the same as your machine. Continuing improvements to the design of this machine may have caused changes that are not included in this manual. The information in this document is subject to change without notice.

## SAFETY INFORMATION

The following safety symbols and signal words will be used throughout this manual and on the product, for your safety and the safety of others, please become familiar with their meaning and heed their warnings.



**This symbol, either used alone or with a signal word, is used to call your attention to instructions involving your safety and/or the safety of others. Failure to follow these instructions will likely result in personal injury or death.**



**DANGER**

**This signal word is used to identify a hazard which, if not avoided, will result in death or serious injury.**



**WARNING**

**This signal word is used to identify a hazard which, if not avoided, could result in death or serious injury.**



**CAUTION**

**This signal word is used to identify a hazard which, if not avoided, could result in minor or moderate injury.**

**NOTICE**

**This signal word is used to identify a hazard which, if not avoided, could result in property or equipment damage. It also may be used for special instructions related to performance, maintenance or general items.**

# SAFETY PRECAUTIONS



## WARNING

**Failure to obey the following safety instructions could result in DEATH or SERIOUS INJURY.**

Read and understand entire manual before operating the Barbed Wire Hog®

For your safety and the safety of others, replace any missing or damaged warning decals by contacting the manufacturer at 1-800-417-9272.

Make sure anyone operating the Barbed Wire Hog® is thoroughly familiar with its operation. Keep all unauthorized and untrained personnel, especially children away from Barbed Wire Hog®.

Never operate machine with guards or safety devices removed or open. Do not alter any safety guards.

Stay clear of barbed wire rolls while Barbed Wire Hog® is being used. Keep all body parts, clothing, jewelry and solid objects away from all moving parts.

Never perform any work on the Barbed Wire Hog® while in use. Before working on or cleaning the Barbed Wire Hog®, shut off engine and disconnect hydraulic supply hoses.

Never operate the Barbed Wire Hog® under the influence of alcohol, drugs, or medications.

This Barbed Wire Hog® has been designed and built as a means to deliver three strands of barbed wire simultaneously, and should not be used for anything other than its intended purpose.

Consult skid steer manufacturers specifications to insure load capacity is not exceeded.

Model	Empty Weight
BWH	1,200 Lbs.(544.3 kg)

Never stand under an elevated Barbed Wire Hog®.

Never attempt to ride the Barbed Wire Hog®.

Always know the location of nearest fire extinguishers, first aid kit, and emergency personnel phone numbers in case of emergency.

# SAFETY PRECAUTIONS



## CAUTION

**Failure to obey the following safety instructions could result in MINOR or MODERATE INJURY.**

Inspect all hoses, fasteners, bolts and welds for nicks, cracks, cuts, damage, wear or looseness before each use. Repair as needed.

Always wear approved PPE, including glasses, glove and hard hats when operating a Barbed Wire Hog®.

Do not use the Barbed Wire Hog® as a lifting device or with accessories or attachments not recommended by EZG Manufacturing, as damage to equipment or operator might result.

Avoid contact with hot hydraulic fluid.

## NOTICE

Use only factory authorized parts.

Used Lubricants such as engine and hydraulic oil, and hazardous waste must be taken to an authorized disposal or recycling center.

### California - Proposition 65 Warning

Engine exhaust and some of its constituents, and some dust created by power sanding, sawing, grinding, drilling, and other construction activities contains chemicals known to the State of California to cause cancer, birth defects and other reproductive harm. Some examples of these chemicals are:

Lead from lead based paints - Crystalline silica from bricks -Cement and other masonry products -Arsenic and chromium from chemically treated lumber

Your risk from these exposures varies, depending on how often you do this type of work. To reduce your exposure to these chemicals: ALWAYS work in a well ventilated area, and work with approved safety equipment, such as dust masks that are specially designed to filter out microscopic particles.

# SETUP INSTRUCTIONS

Before operating the Barbed Wire Hog® it should be properly set up on the jobsite. The Barbed Wire Hog® may be lifted by using a skid steer. The BWH weighs 1200 lbs.(544.3 kg). Check skid steer ratings before attempting to move the Barbed Wire Hog®.

1. Attach the Barbed Wire Hog® to the skid steer.
2. Adapt auxiliary hydraulic quick couplings on skid steer to the hydraulic quick couplings on Barbed Wire Hog® to make a match set.
3. Determine which side of the fence the Barbed Wire Hog® will be dispensing wire. If driving down the inside of the fence (the side without the barb arms) the pivot arm will need to be adjusted such that the pin is in the center hole location. If driving down the outside of the fence (the side with the barb arms) the pivot arm pin hole will need to line up with the full down location. The third pin hole location is for folding the pivot arm down for ease in transporting the unit. *See Page 9 of this Manual for more information.*
4. The vertical arm can be adjusted into 1 of 3 positions: Full down, up 1 foot and up 2 feet. The pin location is approximately half way up the vertical arm.
5. The horizontal arm can be adjusted into 1 of 3 positions: Full in, out 1 foot and out 2 feet. The pin location is near the end of the horizontal arm next to the lower roller guides.
6. If driving over uneven terrain, the hydraulic cylinder can be used to level the Barbed Wire Hog®.
7. Perform the daily maintenance as described in the “Daily Maintenance” section of this manual.
8. Check all hydraulic operations using both levers on the hydraulic control valve.

## LOADING BARBED WIRE

1. Remove pin and top plates of the barbed wire holders and slide the rolls of barbed wire over the center posts. Be sure to load the rolls in such a manner that the wire will feed off the rolls to the INSIDE of the Barbed Wire Hog® in the direction of the pinch rollers.
2. Replace top plates and pins.
3. Release pinch roll latch handles to spread pinch rollers.
4. Feed each strand of barbed wire through the wire guide and OVER the first pinch roller, then BETWEEN the two pinch rollers and then UNDER the second pinch roller.
5. Use the hand crank to assist in feeding the wire between the pinch rollers.
6. Then feed each wire OUTSIDE the lower roller guides, INSIDE the middle roller guides, OUTSIDE the top roller guides and then secure each wire to the termination post.

**Notice! When securing wires to the post, be sure to tension all three strands evenly.**

## LOADING BARBED WIRE (cont.)

7. Lock pinch roll latch handles back down in order to “pinch” the three strands of barbed wire between the pinch rollers.
8. Adjust the springs on the pinch roll latch handles to the desired tension.

## OPERATING INSTRUCTIONS



**Warning! This equipment is to be operated by trained and qualified personnel over the age of 18. Death or serious injury can result.**

1. Attach the Barbed Wire Hog® to the skid steer.
2. Remove pin and adjust pivot arm to desired location and reinsert pin.  
*See Setup Instructions for proper procedure*
3. Remove pin and adjust vertical arm to desired location and reinsert pin.  
*See Setup Instructions for proper procedure.*
4. Remove pin and adjust horizontal arm to desired location and reinsert pin.  
*See Setup Instructions for proper procedure.*
5. Load desired number of rolls of barbed wire.  
*See Loading Barbed Wire for proper procedure.*
6. Drive the skid steer forward and along the fence line. The skid steer driver should move no faster than the speed of which the worker attaching the wire to the barb arms can do such.

**Notice! The skid steer driver must insure that the pivot arm clears the barb arms. The driver must also monitor the tension of the wire to prevent snags or breaks in the wire.**



**Warning! NEVER put your hands near the rolls of barbed wire as they are being dispensed. Serious injury can result.**

7. When the rolls of barb wire are near empty, remove the spent roll, be sure to leave enough wire to splice the new roll. Install new roll and splice the ends.  
*See Step 1 under Loading Barbed Wire for proper procedure.*

**Notice! Do Not release the pinch roll latch handles or separate the pinch rollers. Tension must be kept after the pinch rollers.**





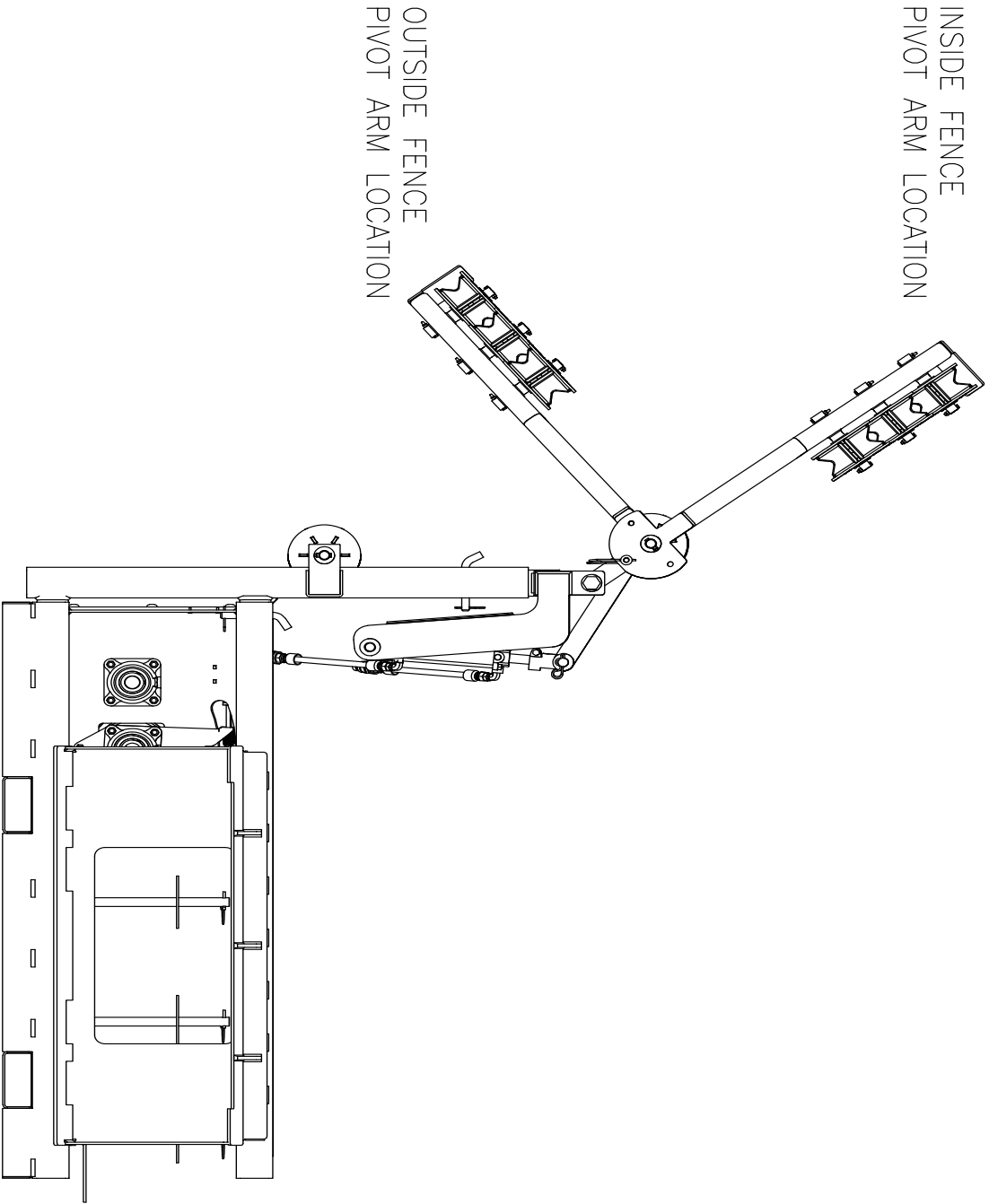

**Barbed Wire Hog Pivot Arm**

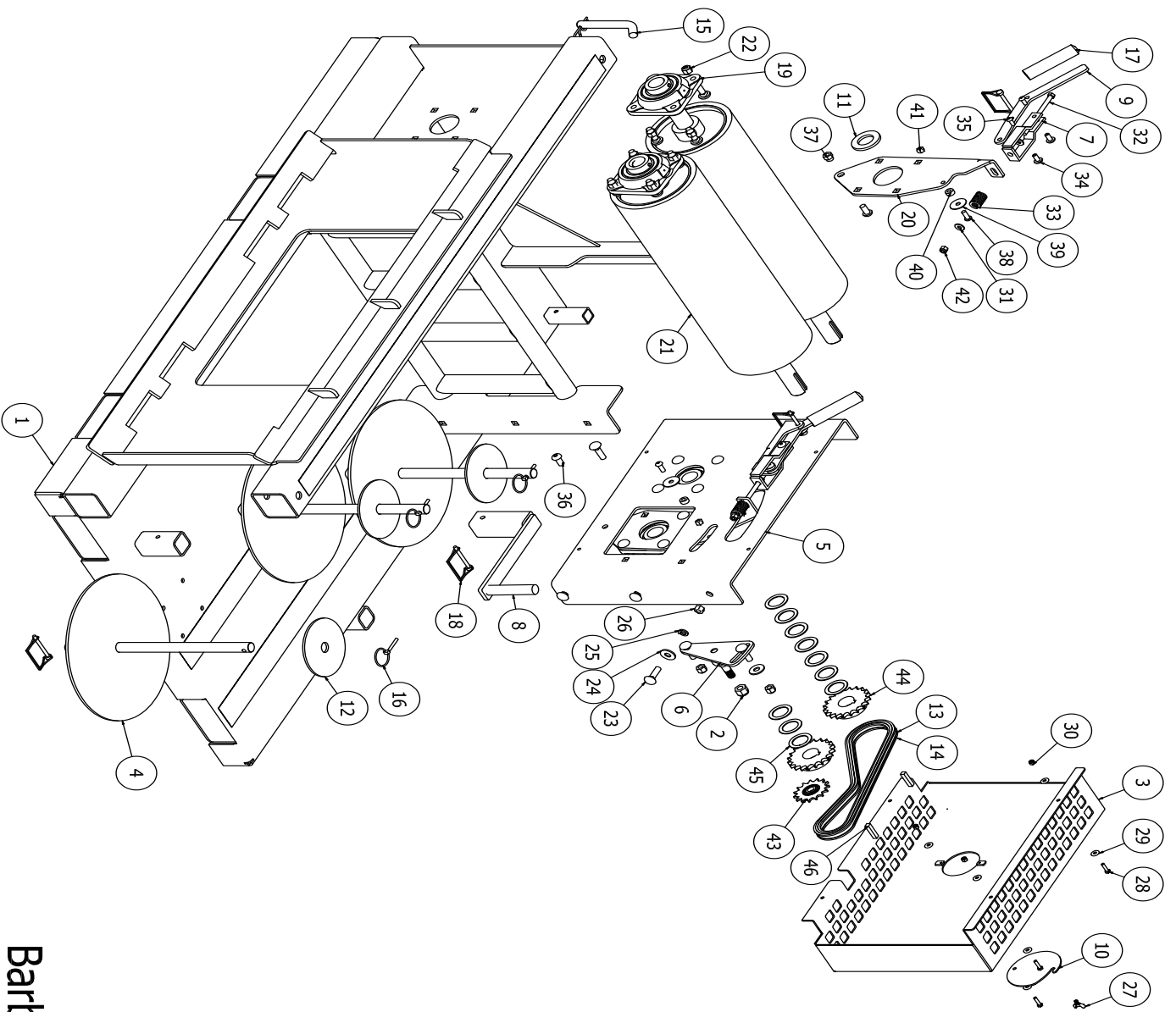

ITEM	QTY	PART NUMBER	DESCRIPTION
1	1	509-A-1	Frame Assembly
2	1	09-210	5/8"-11 Nylon Nut
3	1	509-A-6	Hood Assembly
4	3	509-A-8	Spool Assembly
5	1	509-A-17	Front Roll Support Assembly
6	1	SNG-A-16	SNG Chain Tensioner
7	2	SNG-A-26	SNG "U" For Pinch Roll Tension Handle
8	1	SNG-A-30	SNG Crank Handle Assembly
9	2	SNGH-20	Pinch Roll Latch Handle
10	1	SNG-100	Cover Plate
11	1	SNGH-23	Idle Roll Center Plate, Sprocket Shimms
12	3	509-024	Spool Cap
13	1	15-160	GSSORIV Roller Chain
14	1	15-161	J50 S/C C/L Master Link for #50 Chain
15	1	09-425	10332 Bent Pin 3/4" x 4 1/2"
16	3	09-400	1/4" Linch Pins
17	2	20-147	Cushioned Slide-on Grip
18	6	09-407	5/16" Latch Pin
19	4	15-140	F4BSWC108 Dodge 1 1/2" Bearing
20	2	509-026	Roll Pivot Plate
21	2	509-A-9	Pinch Roll Assembly
22	18	09-208	1/2"-13 Nylon Nut
23	24	09-300	1/2"-13 x 1 3/4" GR5 Carriage Bolt
24	7	09-107	1/2" Flat Washer
25	6	09-103	1/2" Lock Washer
26	6	09-209	1/2"-13 Nut
27	1	09-3026	1/4"-20 x 1/2" Wing Bolt
28	3	09-301	1/4"-20 x 1" GR5 All Thread Bolt
29	6	09-104	1/4" Flat Washer
30	3	09-200	1/4"-20 Nylon Nut
31	4	09-105	5/16" Flat Washer
32	2	09-3007	3/8"-16 x 5 1/2" GR5 Bolt
33	2	09-814	1" OD x 2" Long Die Spring
34	4	09-216	2964 5/16" x 3/4" Barrel Nut
35	4	09-3004	5/16"-18 x 3/4" Button Head Socket Cap Screw
36	2	09-3003	1/2"-20 x 1" Button Head Socket Cap Screw
37	2	09-234-M	1/2"-20 GR8 High Hex Nut
38	2	09-3002	3/8"-16 x 1" Button Head Socket Cap Screw
39	2	09-114	3/8" x 1 1/2" Fender Washer
40	2	15-159	Spacer 3/8" ID 3/4" OD, 3/8" Screw Size
41	2	09-205	3/8"-16 Nut
42	2	09-204	3/8"-16 Nylon Nut
43	1	15-141	Dodge 50BB15H-515H Idlers & Tensioners
44	2	15-143	Martin 50BS20 1 1/2" Sprocket
45	10	09-117	1 1/2" ID, 2" OD Shim-Washer
46	2	15-104	3/8" x 1 3/4" Machined Key (MH Shaft Key)

# Barbed Wire Hog Frame Assembly

ITEM	QTY	PART NUMBER	DESCRIPTION
1	1	509-A-2	Top Pivot Arm Assembly
2	1	509-A-3	Small Pivot Arm Assembly
3	1	509-A-4	Vertical Arm Assembly
4	1	509-A-5	Horizontal Arm Assembly
5	9	509-A-7	Wheel Assembly
6	2	509-A-10	Hose Assembly
7	1	509-A-11	Cylinder Pin Assembly
8	4	509-525	Spacer
9	2	509-519	Wire Wheel Spacer
10	1	509-014	Wire Guard
11	3	509-521	Upper Arm Pin
12	2	509-512	Middle Wire Wheel Pin
13	25	09-118	1" SAE Flat Washer
14	1	09-3030	1" x 8" GR8 Bolt
15	1	09-213	1"-8 Nylon Nut
16	1	65336	1/2" x 5 3/4" Lox All Pin
17	1	09-425	10332 Bent Pin 3/4" x 4 1/2"
18	1	09-400	1/4" Linch Pins
19	2	09-105	5/16" Flat Washer
20	2	09-102	3/8" Lock Washer
21	2	09-307	3/8"-16 x 1" GR5 Bolt
22	7	09-302 (	1/4"-20 x 1 1/2" GR5 Bolt
23	10	09-200	1/4"-20 Nylon Nut
24	3	09-3011	1/4"-20 x 2" GR8 Bolt
25	1	02-713	2" x 6" Tie Rod Cylinder
26	2	02-2061	3/8" MP x 3/8" FPX 90 ELL .032 Restrictor
27	1	02-221	1/2" Female Disconnect
28	1	02-222	1/2" Male Disconnect

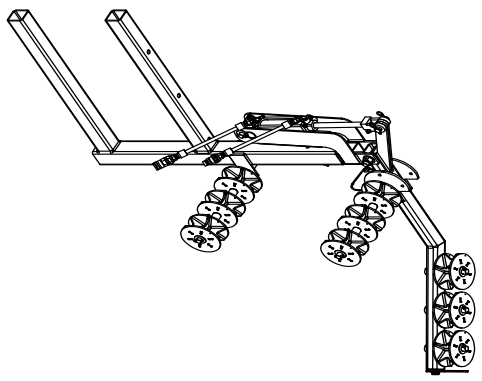
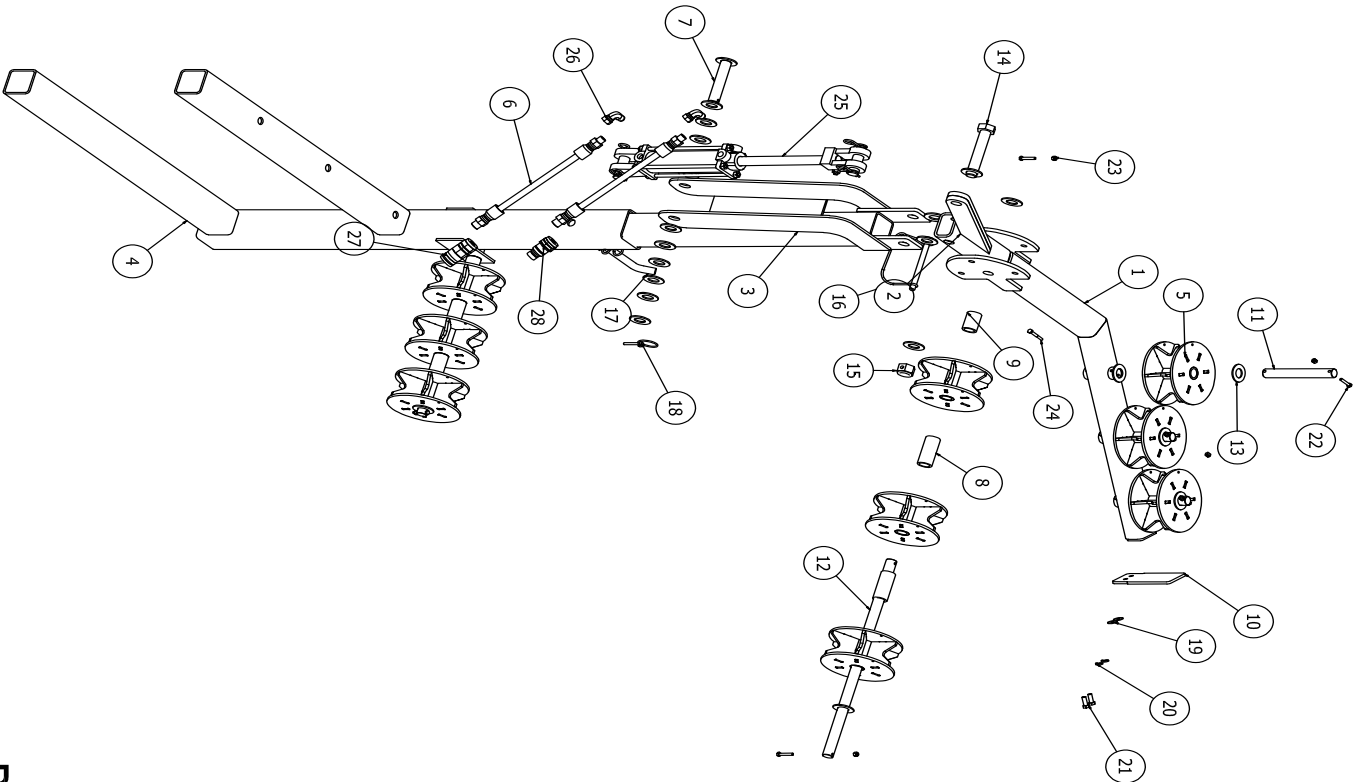

# Barbed Wire Hog Upper Arm Assembly

# TOP TENSION WIRE ATTACHMENT

To install the top tension wire attachment to the Barbed Wire Hog®:

1. Remove the three barbed wire spool holders.
2. Place the top string attachment post (*item #2*)\* to the front of the Barbed Wire Hog® deck and insert pin (*item #3*)\*.
3. Place stringer (*item #5*)\* onto the top string attachment post (*item #2*)\* and insert pin (*item #4*)\*.
4. Remove the outside barbed wire guide wheel and replace it with one of the plastic tension wire guide wheels (*item #1*)\*. Do this for all three outside rollers.
5. Place roll of tension wire on the stringer spool with the wire feeding off the roll to the inside.
6. Release pinch roll latch handles to spread pinch rollers.
7. Feed the tension wire through the wire guide, OVER the first pinch roller, then BETWEEN the two pinch rollers and then UNDER the second pinch roller.
8. Continue feeding the tension wire UNDER the first plastic wire guide roller, OVER the second and then AROUND the top plastic wire guide roller.
9. Lock pinch roll latch handles back down in order to “pinch” the tension wire between the pinch rollers.
10. Adjust the springs on the pinch roll latch handles to the desired tension.

*\*Reference Barbed Wire Hog Top Tension Wire Attachment drawing on page 13 of this manual.*

# Barbed Wire Hog Top Tension Wire Attachments

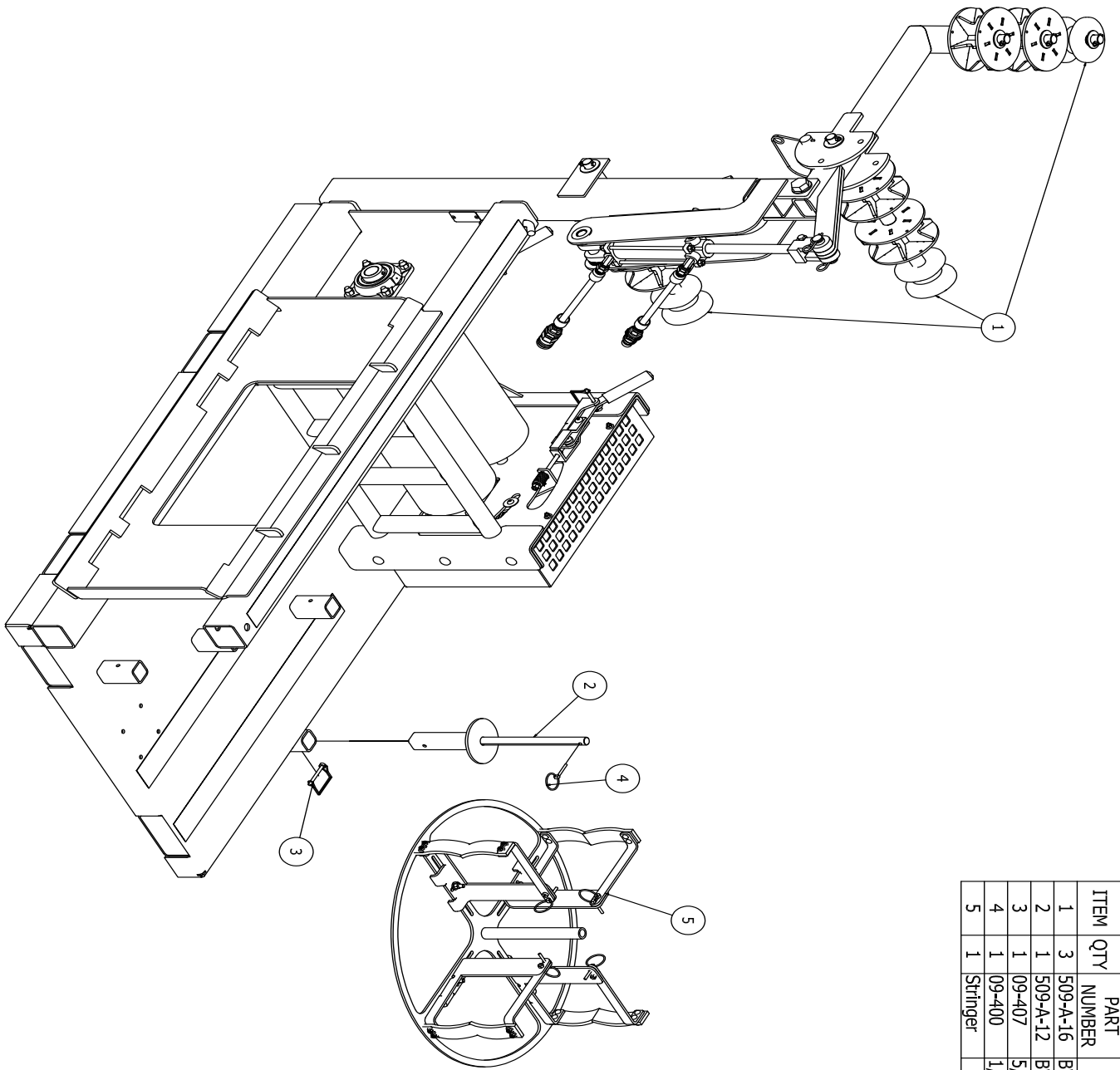

PARTS LIST			DESCRIPTION
ITEM	QTY	PART NUMBER	
1	3	509-A-16	BWH Tension Wire Guide Wheel Assembly
2	1	509-A-12	BWH Top String Attachment Post Assembly
3	1	09-407	5/16" Latch Pin
4	1	09-400	1/4" Linch Pins
5	1	Stringer	

# BOTTOM TENSION WIRE ATTACHMENT

To install the bottom tension wire attachment to the Barbed Wire Hog®:

1. Remove the three barbed wire spool holders.
2. Bolt side spool holder (*item #3*)\*\* to the side of the Barbed Wire Hog® deck.
3. Place bottom string attachment post (*item #1*)\*\* to the side spool holder (*item #3*)\*\* and insert pin (*item #13*)\*\*.
4. Place the stringer (*item #14*)\*\* onto the bottom string attachment post (*item #1*)\*\* and insert pin (*item #12*)\*\*.
5. Bolt the bottom wheel arm (*item #2*)\*\* to the bottom of the horizontal arm.
6. Place the tension wire guide wheel (*item #4*)\*\* onto the bottom wheel arm (*item #2*)\*\* and insert pin (*item #12*)\*\*.
7. Place roll of tension wire on the stringer with the wire feeding off the roll to the inside.
8. Release pinch roll latch handles to spread pinch rollers.
9. Feed the tension wire through the wire guide, OVER the first pinch roller, then BETWEEN the two pinch rollers and then UNDER the second pinch roller.
10. Continue feeding the tension wire AROUND the tension wire guide wheel (*item #4*)\*\*.
11. Secure the tension wire to the termination post.
12. Lock pivot plate handles back down in order to “pinch” the tension wire between the pinch rollers.
13. Adjust the springs on the pinch roll latch handles to the desired tension.

*\*\*Reference Barbed Wire Hog Bottom Tension Wire Attachment drawing on page 15 of this manual.*

# Barbed Wire Hog Bottom Tension Wire Attachments

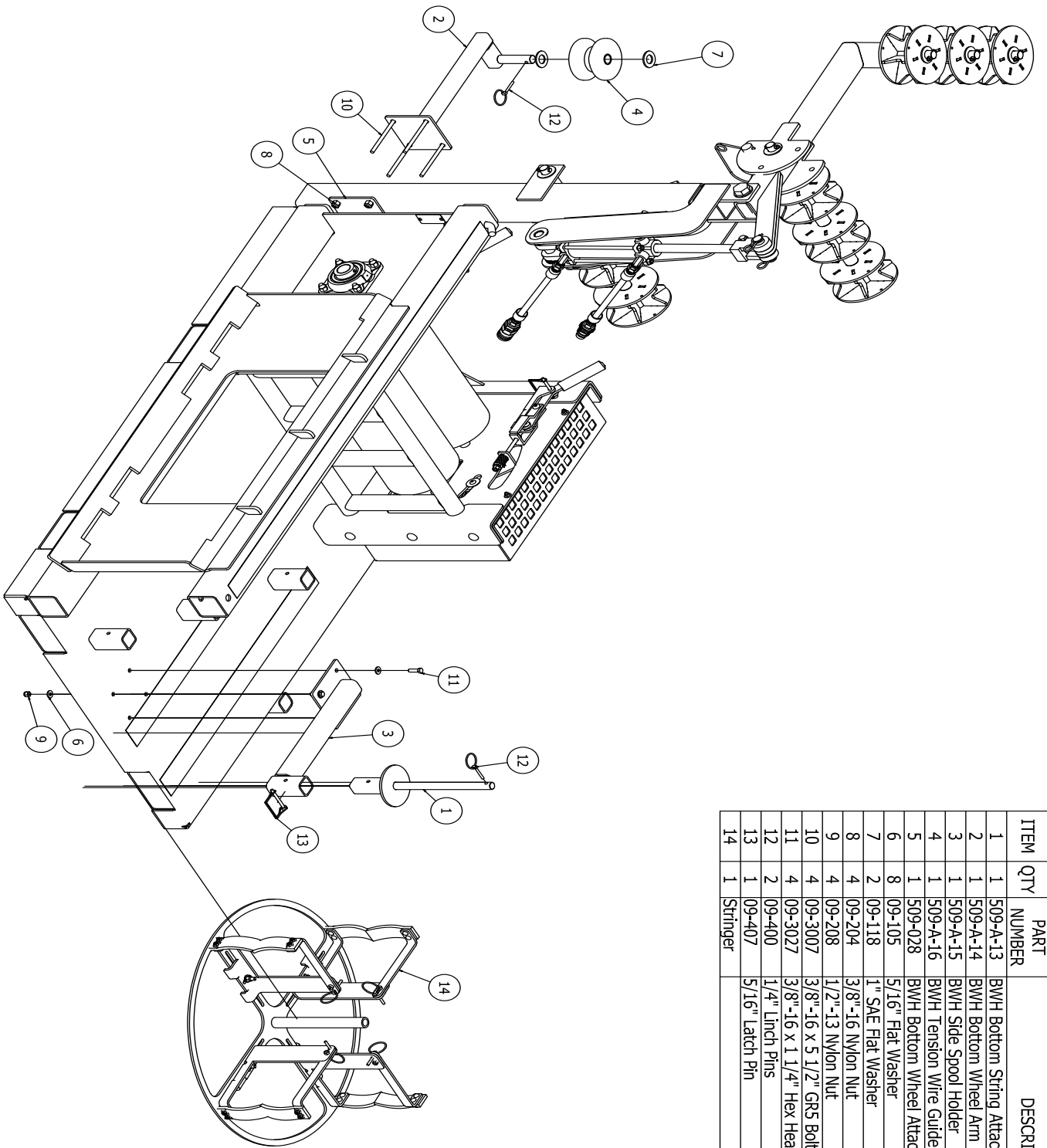

PARTS LIST			DESCRIPTION
ITEM NUMBER	QTY	PART NUMBER	
1	1	509-A-13	BW/H Bottom String Attachment Post Assembly
2	1	509-A-14	BW/H Bottom Wheel Arm
3	1	509-A-15	BW/H Side Spool Holder
4	1	509-A-16	BW/H Tension Wire Guide Wheel Assembly
5	1	509-028	BW/H Bottom Wheel Attachment Plate
6	8	09-105	5/16" Flat Washer
7	2	09-118	1" SAE Flat Washer
8	4	09-204	3/8"-16 Nylon Nut
9	4	09-208	1/2"-13 Nylon Nut
10	4	09-3007	3/8"-16 x 5 1/2" GR5 Bolt
11	4	09-3027	3/8"-16 x 1 1/4" Hex Head Bolt
12	2	09-400	1/4" Linch Pins
13	1	09-407	5/16" Latch Pin
14	1	Stringer	

# WARNING LABELS AND LOCATIONS

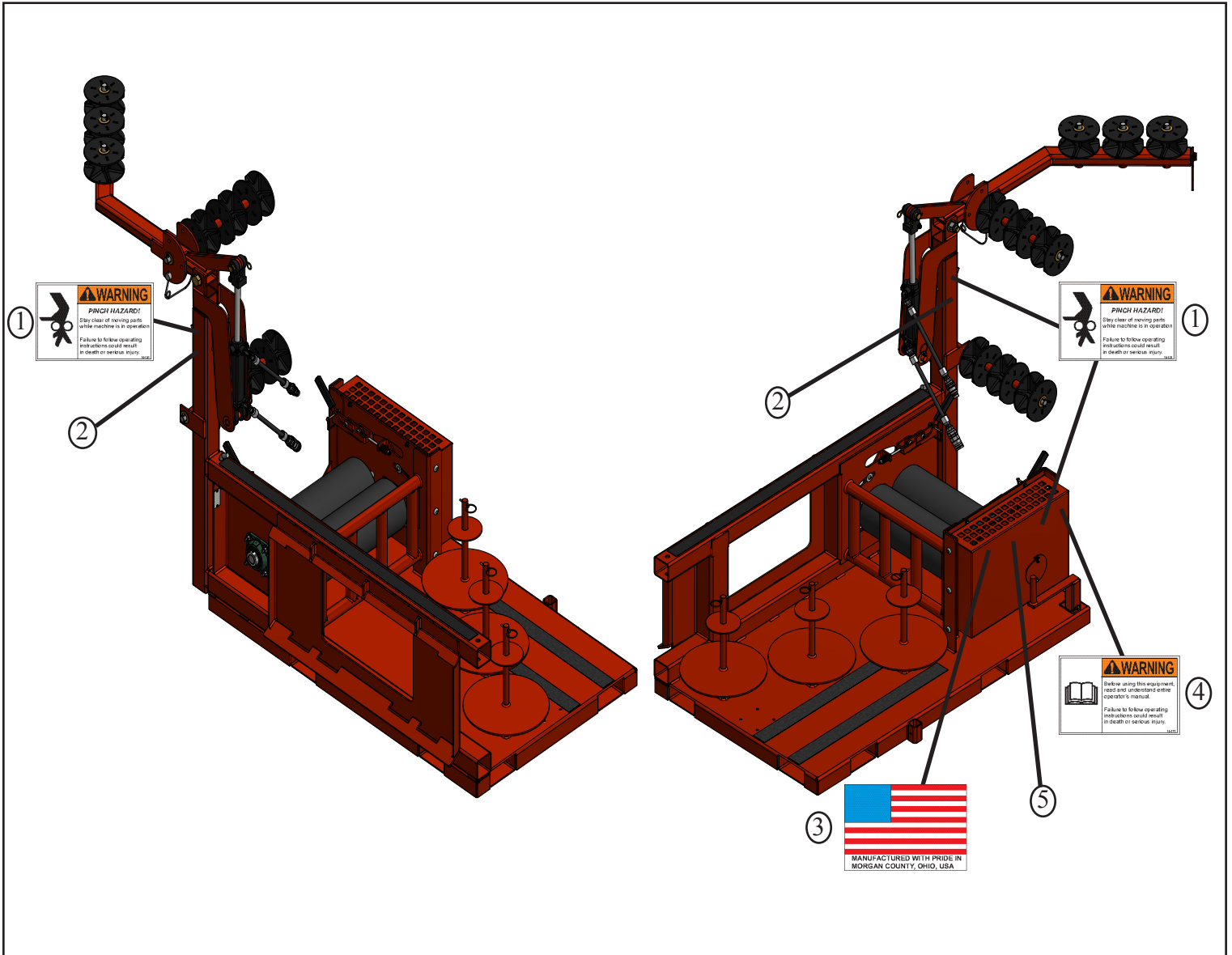

ITEM	PART NUMBER	DESCRIPTION	QTY
1	16-131	Small Pinch Point Decal	3
2	16-***	Grease Daily Decal	2
3	16-106	U.S. Flag Decal	1
4	16-177	Read Owners Manual Decal	1
5	16-***	Excessive Tension Decal	1

\*\*\*Consult Factory





# WARRANTY

## Limited Warranty

The manufacturer warrants that products manufactured shall be free from defects in material and workmanship that develop under normal use for a period of one year on all products from the date of shipment. The foregoing shall be the exclusive remedy of the buyer and the exclusive liability of the manufacturer. Our warranty excludes normal replaceable wear items, i.e. gaskets, wear parts, seals, O-rings, belts, drive chains, clutches, etc. Any equipment, part or product which is furnished by the manufacturer but manufactured by another, bears only the warranty given by such other manufacturer. (Manufacturer agrees to furnish free of charge a written description of problem or cause.) Warranty is voided by product abuse, alterations, use of equipment in applications for which it was not intended, use of non-manufacturer parts, or failure to follow documented service instructions. The foregoing warranty is exclusive of all other warranties whether written or oral, expressed or implied. No warranty of merchantability or fitness for a particular purpose shall apply. The agents, dealers, and employees of Manufacturer are not authorized to make modifications to this warranty, or additional warranties binding on the Manufacturer. Therefore, additional statements, whether oral or written, do not constitute warranty and should not be relied upon.

The Manufacturer's sole responsibility for any breach of the foregoing warranty provisions, with respect to any product or part not conforming to the Warranty or the description herein contained, is at its option (a) to repair, replace, or refund such product or parts upon the prepaid return thereof to location designated specifically by the Manufacturer. Product returns not shipped prepaid will be refused (b) as an alternative to the foregoing modes of settlement- the Manufacturer's dealer may repair defective units with reimbursement for expenses. A written description of problem or cause must accompany all warranty claims.

Except as set forth here in above and without limitation of the above, there are no warranties or other affirmation which extend beyond the description of the products on the fact here of, or as to operational efficiency, product reliability, or maintainability or compatibility with products furnished by others. In no event, whether as a result of breach of contract or warranty or alleged negligence, shall the Manufacturer, be liable for special or consequential damages including but not limited to: Loss of profits or revenue, loss of use of the product or any associated product, cost of capital, cost of substitute products, facilities or services or claims of customers. Manufacturer does not assume responsibility for any accident due to equipment modification.

No claim will be allowed for products lost or damaged in transit. Such claims should be filed with the carrier within fifteen days.

Effective July 20, 2005

EZG Manufacturing is the exclusive manufacturer of the patented Grout Hog® Grout Delivery System the Mud Hog® Hydraulic Mixing Station, the Hog Trough® mud pan, the Hog Cart™, the Hog Slopper™, the Booger Hog® Wall Scrubber, the Hog Leg® Wall Brace System, and the Hog Crusher™ Material Recycling System.

Fax Warranty Registration form to 740-962-2037  
or submit online at [www.ezgmfg.com](http://www.ezgmfg.com) by clicking  
on “Products” then “Warranty Cards”.

## WARRANTY REGISTRATION

CONTACT: \_\_\_\_\_

COMPANY: \_\_\_\_\_

ADDRESS: \_\_\_\_\_

CITY: \_\_\_\_\_ STATE: \_\_\_\_\_ ZIP: \_\_\_\_\_

TEL: (\_\_\_\_) \_\_\_\_ - \_\_\_\_ FAX: (\_\_\_\_) \_\_\_\_ - \_\_\_\_ CELL: (\_\_\_\_) \_\_\_\_ - \_\_\_\_

EMAIL: \_\_\_\_\_

PURCHASED FROM:  Direct  Distributor: \_\_\_\_\_

PURCHASE DATE: \_\_\_\_\_ SERIAL NO. \_\_\_\_\_

**PLEASE COMPLETE THIS WARRANTY CARD, AND RETURN VIA MAIL, FAX, OR E-MAIL,  
WITHIN 30 DAYS OF PURCHASE TO VALIDATE YOUR MANUFACTURER'S WARRANTY  
FOR ALL EZG MANUFACTURING PRODUCTS.**

**WARRANTY PROVISIONS OF THIS MACHINE ARE HANDLED DIRECTLY THROUGH  
THE MANUFACTURER.**

**EZG MANUFACTURING \* 1833 North Riverview Road, Malta, OH 43758 \***

**PHONE 1-800-417-9272 \* Email: [warranty@ezgmfg.com](mailto:warranty@ezgmfg.com) \* FAX 740-962-2037**

*Please take a minute to fill out the survey below so that we can better serve our customers.*

## EZ Survey

**1. WHERE DID YOU FIRST HEAR ABOUT EZG MANUFACTURING? (CHECK ONE)**

Masonry Magazine  Website  Newsletter  Referral  Masonry Construction

Other: \_\_\_\_\_

**2. WHAT INFLUENCED YOU TO BUY?  QUALITY  PRICE  EASY TO USE  OTHER**

**3. WHO IS YOUR SALES REPRESENTATIVE? \_\_\_\_\_**

**4. ARE YOU SATISFIED WITH THE CUSTOMER SERVICE YOU RECEIVED?  YES  NO**

**Explain:** \_\_\_\_\_

**5. WHAT OTHER EZG MANUFACTURING PRODUCTS DO YOU OWN?**

\_\_\_\_\_  
\_\_\_\_\_

**6. WOULD YOU LIKE TO BE FEATURED IN OUR NEWSLETTER?  YES  NO**

**If yes, where can we reach you and what is the best time?**

\_\_\_\_\_  
\_\_\_\_\_

**Comments:** \_\_\_\_\_

\_\_\_\_\_  
\_\_\_\_\_