



Before using this equipment,  
study and understand entire  
Owner's Manual.

Serial Number \_\_\_\_\_

# 38 Special Pump Parts Manual

(Includes)

**HP38 Trailer Mounted**  
**HP38SM Skid Mounted**  
**HP38SS Skid Steer**



**38 Special Pump**  
**EZG Manufacturing**  
**1-800-417-9272**

**EZG Manufacturing**  
**405 Watertown Road**  
**Waterford, Ohio 45786**

**(740) 749-3512 or 1-800-417-9272**  
**Fax (740) 962-2037 [www.ezgmfg.com](http://www.ezgmfg.com)**

# TABLE OF CONTENTS

Routine Maintenance Items.....	2
General Information .....	2
About This Manual .....	2
HP38BUAssembly.....	3
HP38SSAssembly.....	6
HP38SS Hydraulic Assembly.....	8
HP38SM Assembly .....	9
Engine .....	14
HP38 Assembly .....	16
HP38SM/HP38HydraulicAssembly .....	19
Notes .....	21

<b>Routine Maintenance Items for HP-38 / HP-38SM</b>		
<b>Part Number</b>	<b>Description</b>	<b>Qty</b>
14-2055	Fuel Filter	1
14-2056	Primary Air Filter Element	1
14-2057	Pre-cleaner Air Filter Element	1
14-2058	Oil Filter	1
14-2059	Spark Plug	2
20-1020	20W-50 Oil Synthetic Blend	2 qts (1.9L)

## GENERAL INFORMATION

Illustrations throughout this manual are representative and may show details or components that may not be the same as your machine. Continuing machine design improvements may cause changes not included in this manual. The information in this document is subject to change without any prior notice.

## ABOUT THIS MANUAL

This manual is provided with the HP 38 Special Trailer, Skid Mount, and Skid Steer units to inform the equipment owner/operator how to visually locate various components and their part identification number for the purpose of ordering parts that may need replaced due to regular maintenance, wear, or damage. This manual is not intended for the purpose of operating, safety, warranty, or registration of the HP 38 Special units. If you do not understand any items in this manual, please contact the dealer where this product was purchased or the manufacturer at the number listed throughout this manual. If you have any suggestions about how to make this manual easier to understand, contact the manufacturer. Keep this manual available for reference wherever this piece of equipment is being used and make it available to any operators.

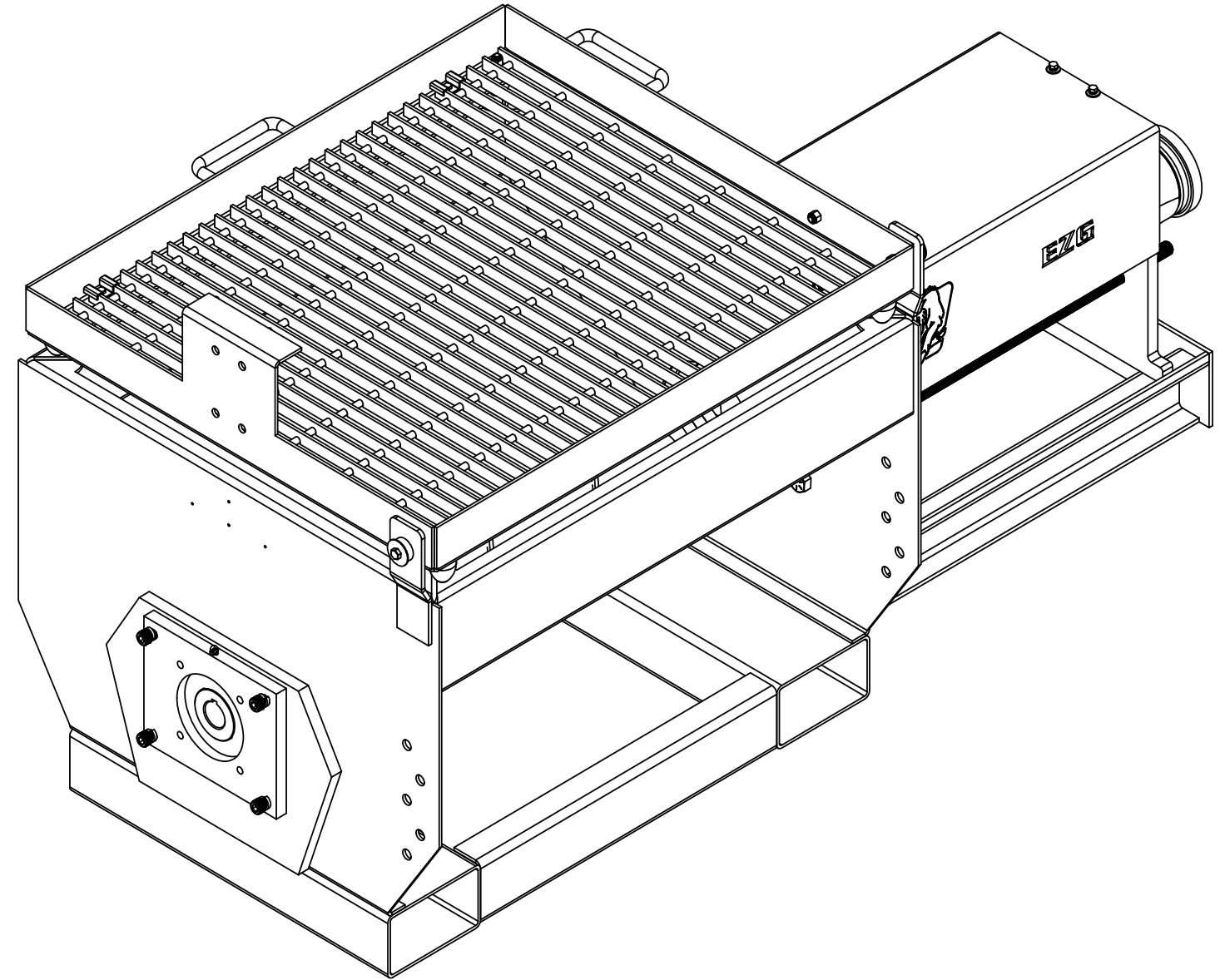

# HP38BU BASE UNIT

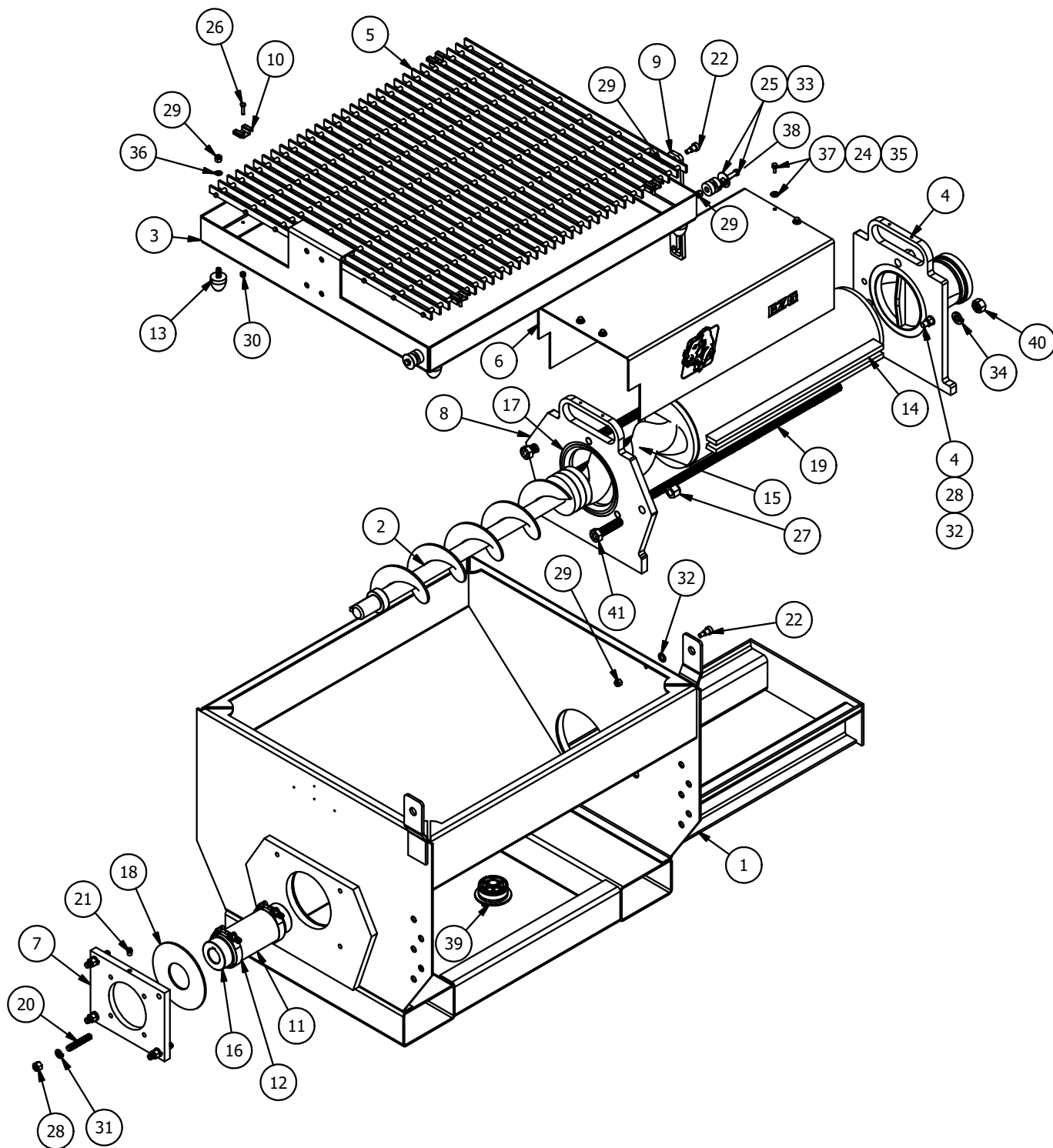

## HP38BU ASSEMBLY

PARTS LIST			
ITEM	QTY	PART NUMBER	DESCRIPTION
1	1	1100-A-01	Welded Base Assembly
2	1	1100-A-02	Shaft Assembly
3	1	1100-A-03	Grate Frame Welded Assembly
4	1	1100-A-04	HP38-Discharge Nozzle Welded Assembly
5	1	1100-502	HP38 - Hopper Grate
6	1	1100-016	Stator Cover
7	1	1100-015	HP38 - Hydraulic Motor Mount Plate
8	1	1100-013	Hopper Outlet Plate
9	1	1100-010	HP38 - Grate Prop Bar
10	4	20-1015	Bar Grating Clip (HP-38)
11	1	20-1014	3"IDx3-1/2"OD Abrasion Res. Hose (HP-38)
12	2	20-1012	3 9/32 to 3 19/32 ID Hose Clamp
13	4	20-1011	3/8-16 x 1 1/2 OD Threaded Stud Bumper
14	1	20-208	Stator 2L8 SPD
15	1	20-207	Rotor 2L8
16	1	15-1016	7/16 Hub 3/8 U-Joint (HP-38)
17	1	13-189	1/4 Width 442 Dash Number O-Ring
18	1	13-188	Grease Seal (HP-38)
19	3	09-3231	3/4-10 All Thread x 3'
20	4	09-3229	1/2-13 x 3 All Thread
21	1	09-600	1/8" NPT 90 Degree Grease Fitting
22	2	09-334	1/2" x 1/2" x 3/8" Thread Shoulder Screw
23	1	09-328	1/2" -13 x 2" GR8 Bolt
24	4	09-322	1/4"- 20 x 3/4" GR5 Bolt
25	2	09-312	3/8"-16 x 2" GR5 Bolt
26	4	09-301	1/4"-20 x 1" GR5 All Thread Bolt
27	2	09-236	3/4" Nylon Nut
28	5	09-208	1/2" -13 Nylon Nut
29	8	09-204	3/8"-16 Nylon Nut
30	4	09-200	1/4"-20 Nylon Nut
31	4	91102A770	1/2" Lockwasher
32	2	09-119	Shim 3/40" Thick x 1/2" ID x 7/8" OD
33	2	09-114	3/8" x 1 1/2" Fender Washer
34	3	09-113	3/4" Lock Washer
35	4	09-104	1/4" Flat Washer
36	4	09-102	3/8" Lock Washer
37	4	09-100	1/4" Lock Washer
38	2	02-803	2-Piece Vibration Mount Neoprene
39	1	01-775	Wing Nut Expansion Plug for 3" Pipe
40	3	94895A036	3/4"-10 GR8 Nut
41	2	92620A847	3/4-10 x 3 Fully Threaded Hex Head GR8 Zinc Plt

## HP38BU ASSEMBLY PARTS LIST

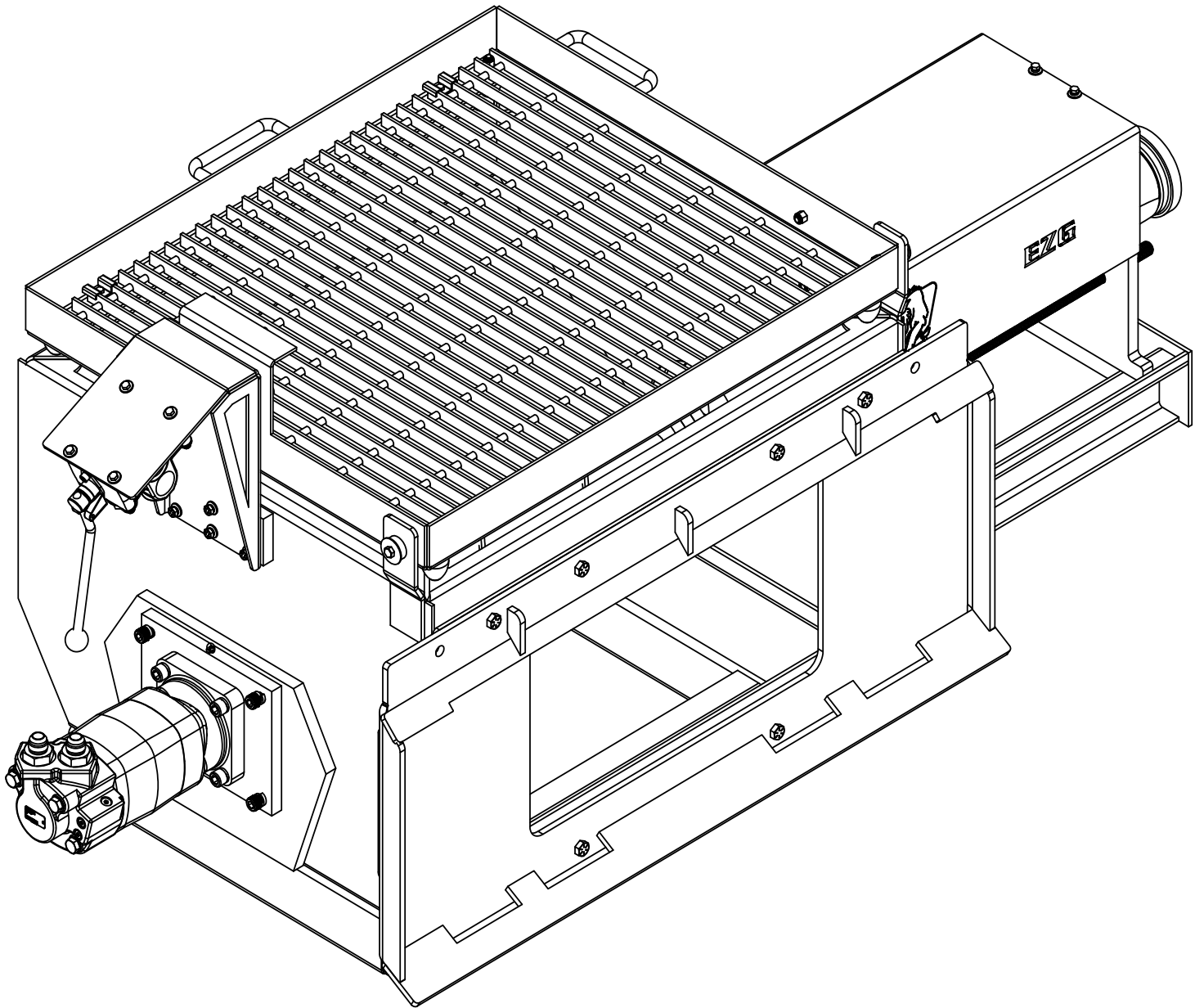

**HP38SS SKID STEER**  
(hydraulic lines not shown for clarity)

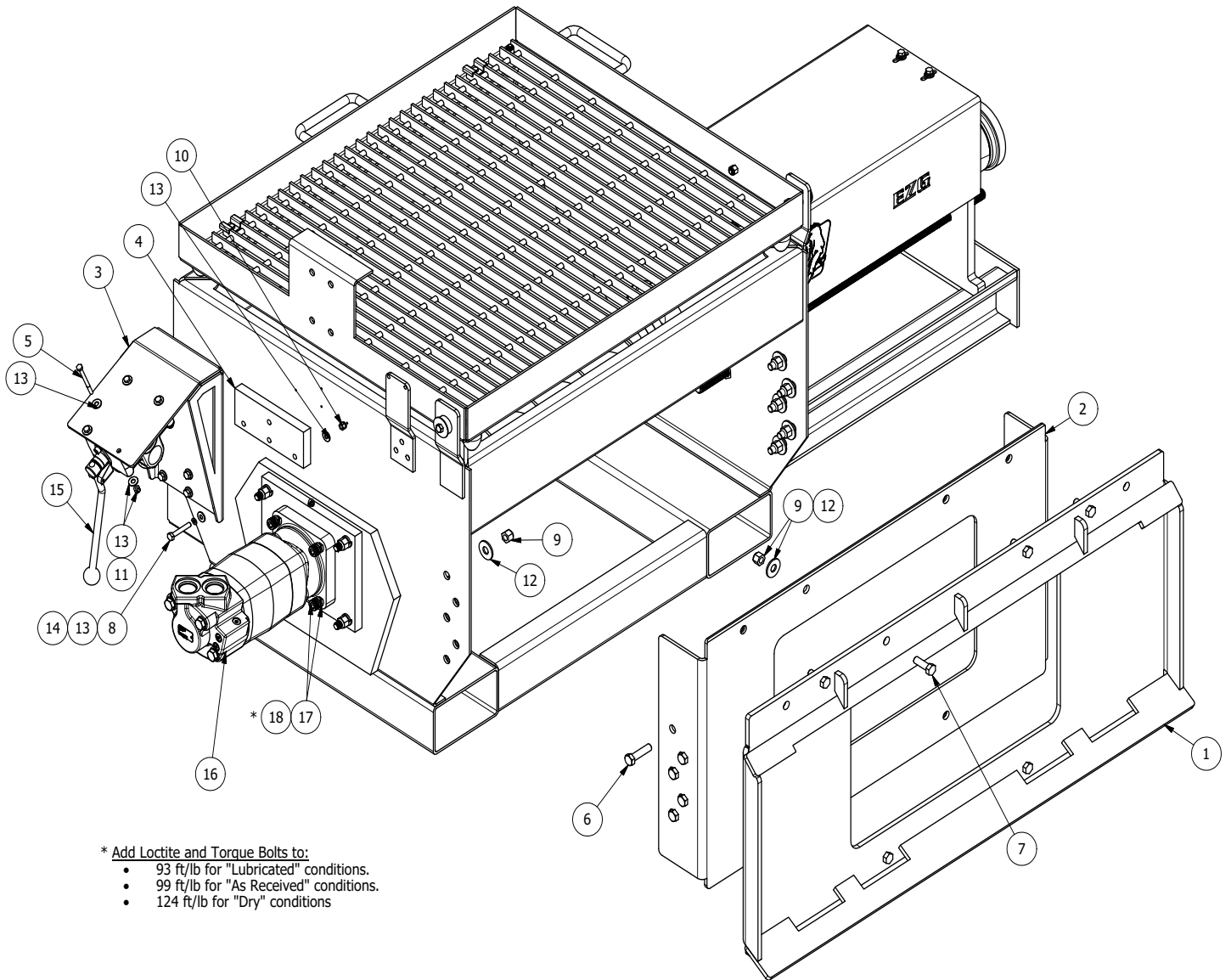

- \* Add Loctite and Torque Bolts to:
- 93 ft/lb for "Lubricated" conditions.
  - 99 ft/lb for "As Received" conditions.
  - 124 ft/lb for "Dry" conditions

PARTS LIST				
ITEM	QTY	PART NUMBER	DESCRIPTION	
1	1	FH-A-9	FH24 36 Univers. Attach. Plate. Large	
2	1	1100-019	Attachment Plate	
3	1	1100-017	Valve Mount Plate	
4	1	1100-007	Valve Mount Spacer Plate	
5	4	09-388	1/4"-20 x 3" GR8 Bolt)	
6	10	09-328	1/2" -13 x 2" GR8 Bolt	
7	6	09-317	1/2"-13 x 1-1/2" in. GR5 Bolt	
8	4	09-305	5/16"-18 x 2" GR5 Bolt	
9	16	09-208	1/2" -13 Nylon Nut	
10	4	09-202	5/16"-18 Nylon Nut	
11	4	09-200	1/4"-20 Nylon Nut	
12	16	09-107	1/2" Flat Washer	
13	16	09-104	1/4" Flat Washer	
14	4	09-100	1/4" Lock Washer	
15	1	02-6088	Proportional Manual Hydr Valve (HP-38)	
16	1	02-4008	BMK6-1000 Hydraulic Motor	
17	4	09-3230	1/2-13 x 1 3/4 Socket Head Screw	
* 18	4	09-122	1/2" Wedge Lock Washer	

## HP38SS ASSEMBLY

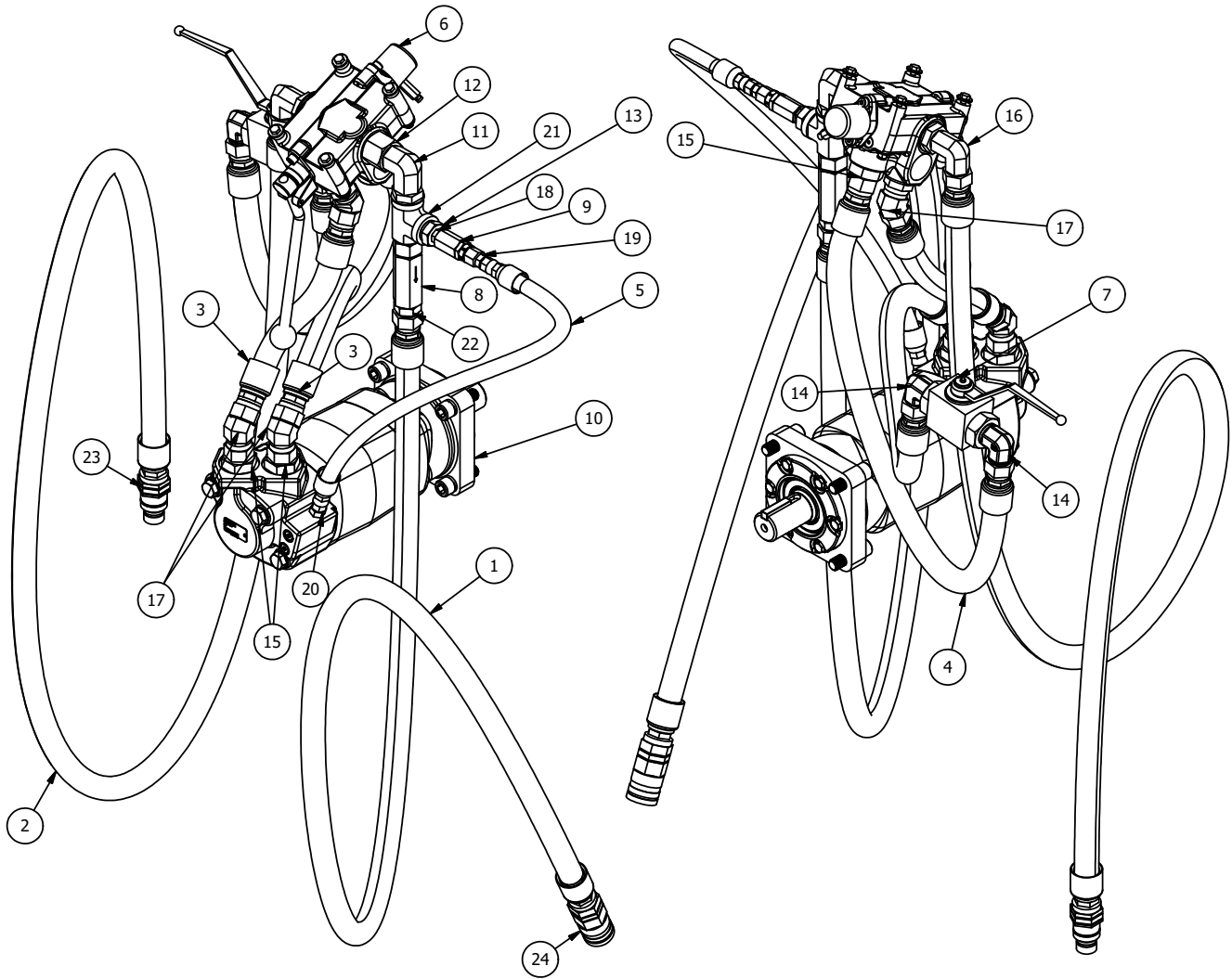

PARTS LIST				PARTS LIST			
ITEM	QTY	PART NUMBER	DESCRIPTION	ITEM	QTY	PART NUMBER	DESCRIPTION
1	1	1100-A-22	HP38SS-Hose- Female QD to CV Out	13	1	02-2164	3/4" MP x 1/4" FP - Reducer Bushing - Steel
2	1	1100-A-23	HP38SS-Hose- Male QD to Valve P	14	2	02-2162	3/4" JICM x 3/4" NPTM 90° Adapter
3	2	1100-A-24	HP38SS-Motor"A"-Valve"A"/Motor"B"SOV	15	4	02-2160	3/4 JICM x 1" ORBM Straight Adapter
4	1	1100-A-25	HP38SS-Hose-Valve"B"to Shut Off Valve	16	1	02-2111	3/4" JICM to 1" ORBM 90 Elbow
5	1	1100-A-26	HP38SS-Hose-Motor Case Drain-Check Valve	17	3	02-2099	3/4" JICM x 3/4" JICF Swivel 45° Nut Elbow
6	1	02-6088	Proportional Manual Hydr Valve (HP-38)	18	1	02-2073	1/4 Male Pipe x 1/4 Male Pipe Hex Nipple
7	1	02-6089	3/4" NPT HP Shut Off Valve	19	1	02-2072	3/8 JICM x 1/4 Male Pipe Conn
8	1	02-6090	3/4 NPT Check Valve (HP-38)	20	1	02-2063	3/8" JICM to 1/4" ORBM Straight Adaptor
9	1	02-6091	1/4" NPT Check Valve	21	1	02-291	3/4" NPTM to 3/4" NPTF to 3/4" NPTF Tee
10	1	02-4008	BMK6-1000 Hydraulic Motor	22	1	02-290	2404-12-12 3/4" Pipe to 3/4" JIC
11	1	02-2166	3/4" ORBM x 3/4" NPTM 90° Adapter)	23	1	02-222	1/2" Male Disconnect
12	1	02-2165	1" ORBM x 3/4 ORBF Reducer/Expander	24	1	02-221	1/2" Female Disconnect

## HP38SS HYDRAULIC ASSEMBLY



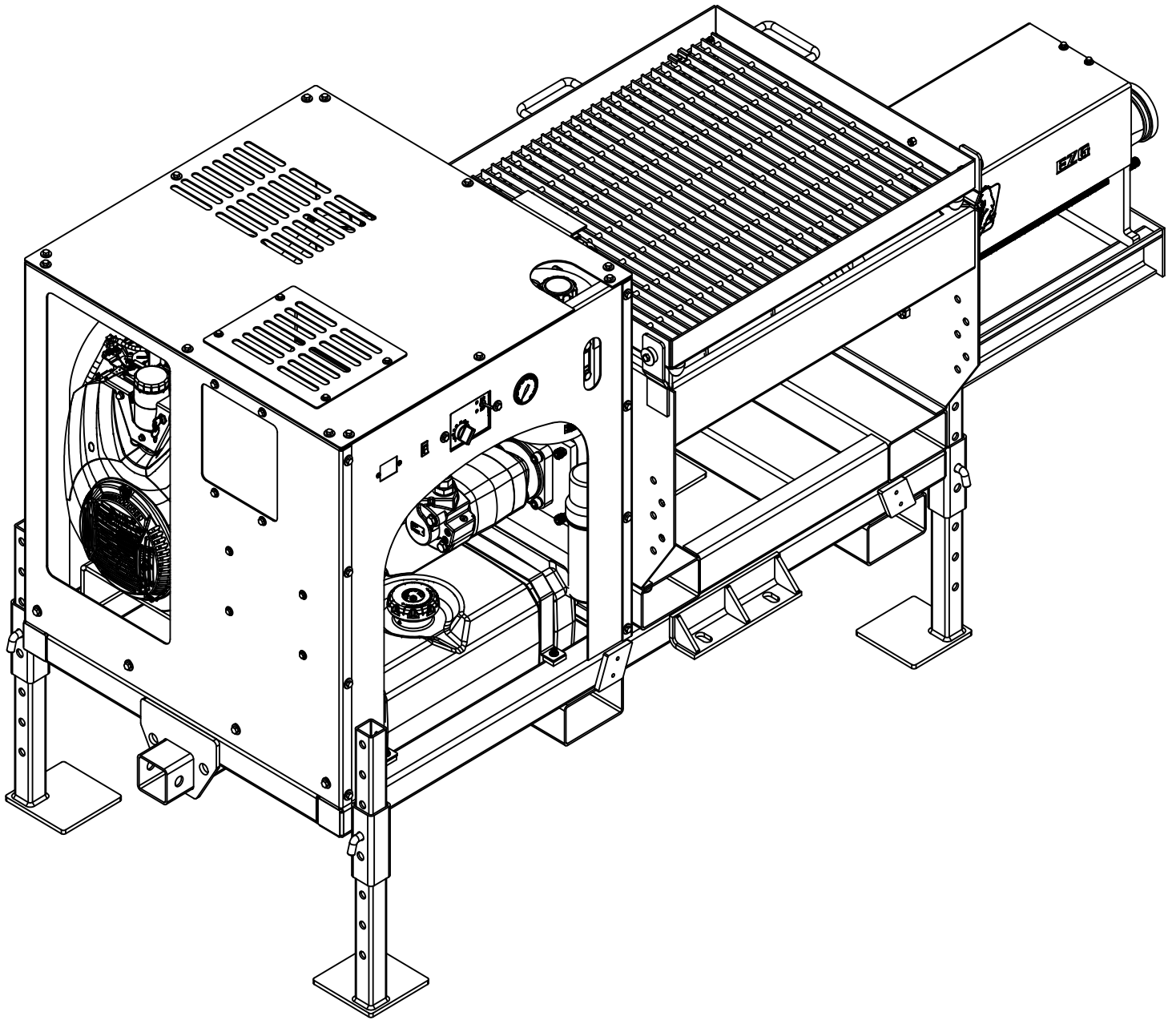

**HP38SM SKID MOUNTED /  
HP38 TRAILER MOUNTED  
ASSEMBLIES**

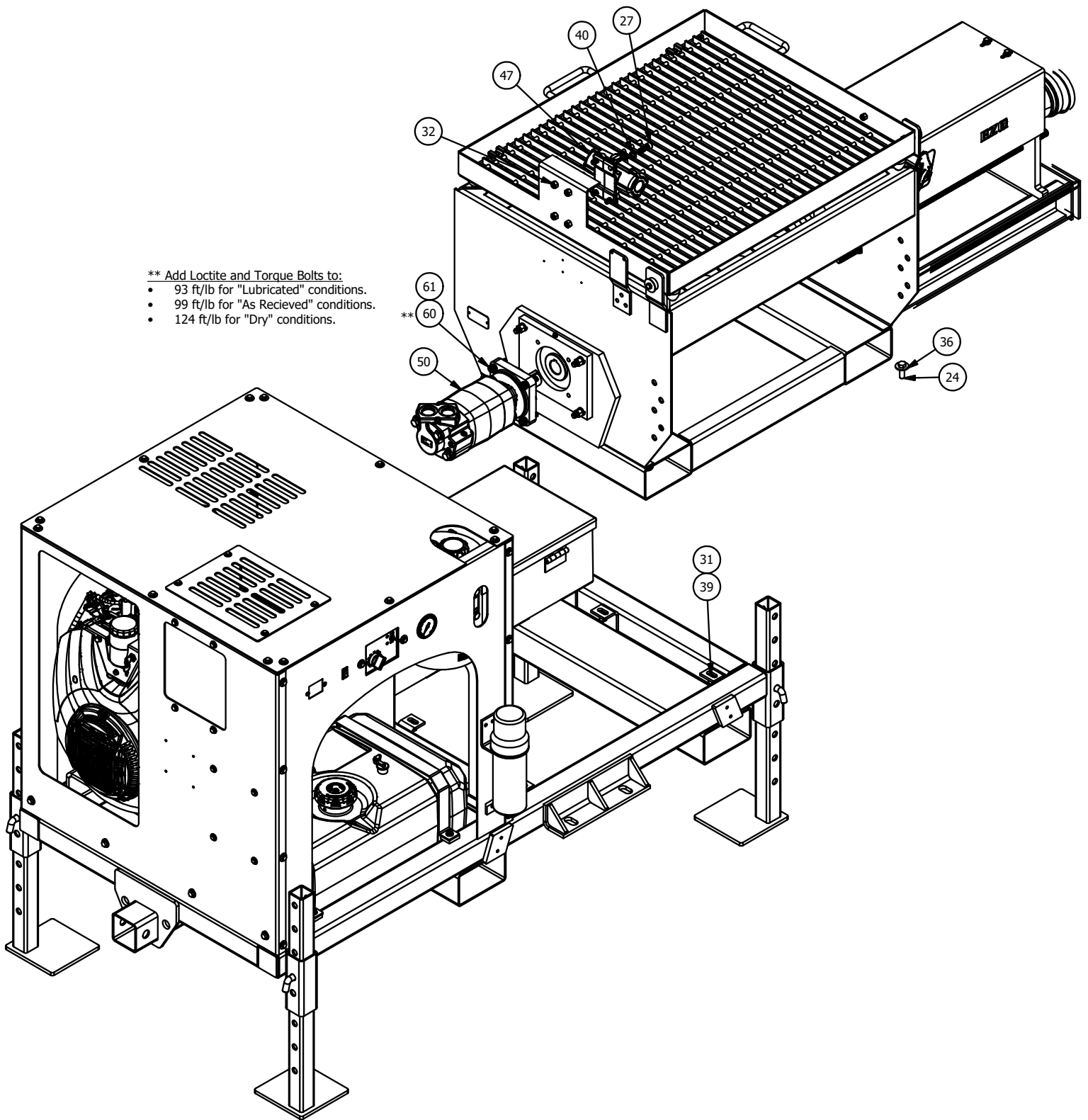

## HP38SM / HP38 ASSEMBLY

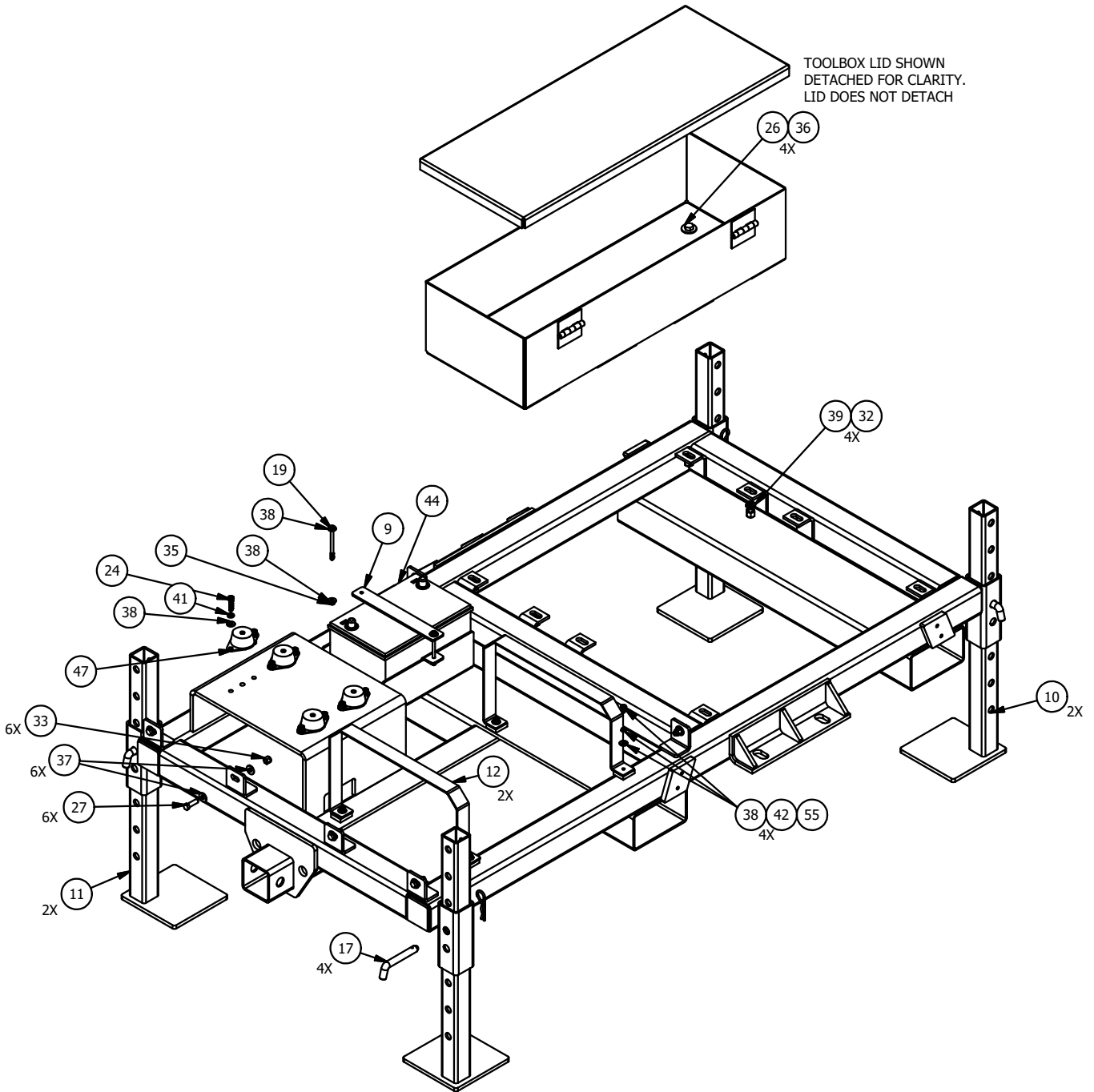

## HP38SM / HP38 ASSEMBLY

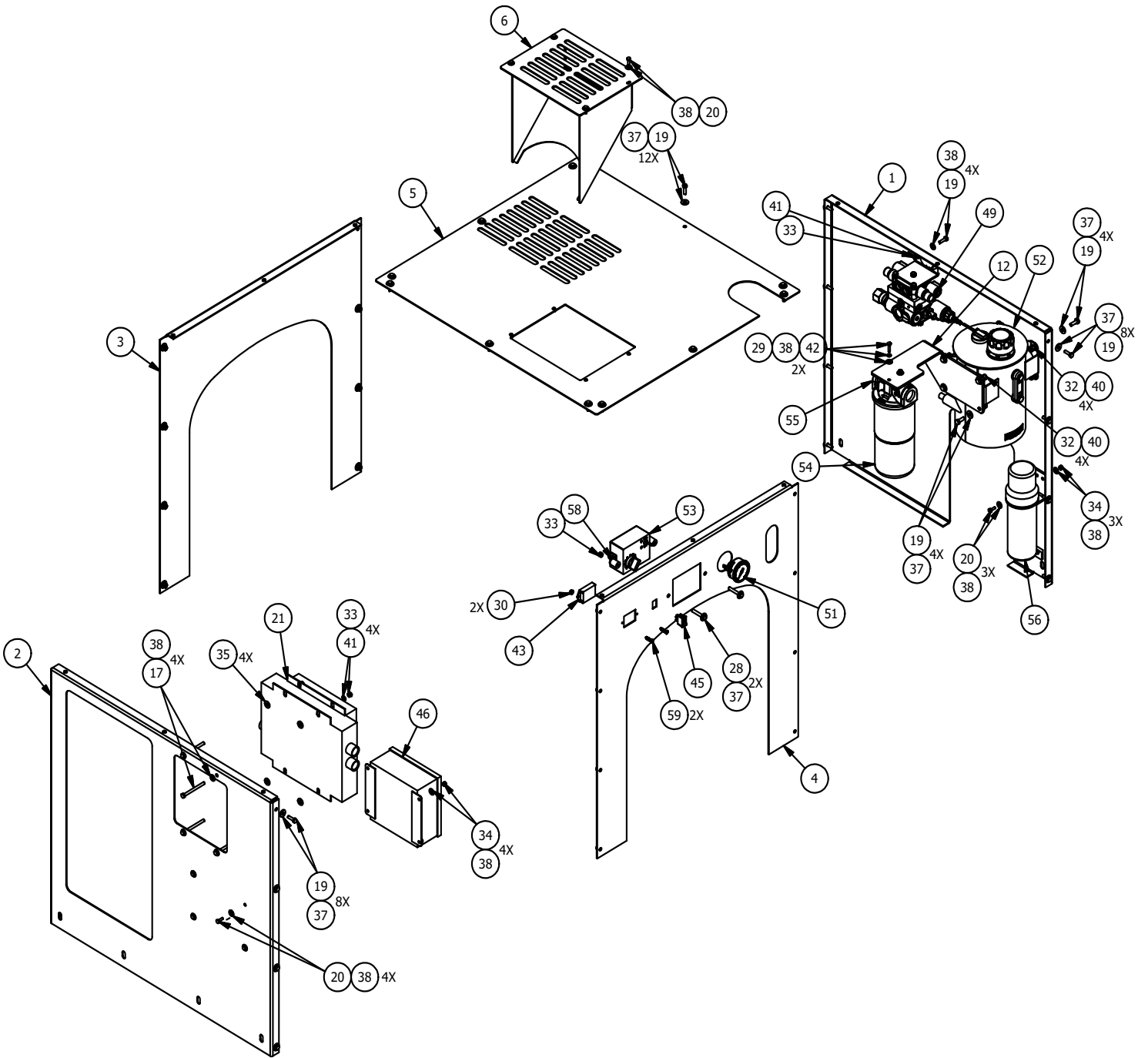

## HP38SM / HP38 ASSEMBLY

PARTS LIST				PARTS LIST			
ITEM	QTY	PART NUMBER	DESCRIPTION	ITEM	QTY	PART NUMBER	DESCRIPTION
1	1	1100-A-21	Rear Panel w/ Hardware Assembly	31	8	09-208	1/2"-13 Nylon Nut
2	1	1100-A-20	Front Panel w/ Hardware Assembly	* 32	18	09-204	3/8"-16 Nylon Nut
3	1	1100-A-19	Engine Side Panel w/ Hardware Assembly	33	33	09-202	5/16"-18 Nylon Nut
4	1	1100-A-18	Fuel Side Panel w/ Hardware Assembly	34	6	09-200	1/4"-20 Nylon Nut
5	1	1100-A-10	HP-38 - Top Panel w/ Hardware Assembly	35	4	09-172	3/8 Rubber Sealing Washer
6	1	1100-A-09	HP38 - Heat Shroud Welded Assembly	36	8	09-107	1/2" Flat Washer
7	1	1100-A-06	HP38 - Tool Box Welded Assembly	37	70	09-105	5/16" Flat Washer
8	1	1100-A-05	HP38-Trailer Unit Frame Welded Assembly	38	46	09-104	1/4" Flat Washer
9	2	MH12-A-91	MH12-Back Left/Front Right Leg Assembly	39	8	09-103	1/2" Lock Washer
10	2	MH12-A-90	MH12- Back Right/Front Left Leg Assembly	* 40	16	09-102	3/8" Lock Washer
11	2	1100-038	HP38 - Fuel Tank Strap	41	15	09-101	5/16" Lock Washer
12	1	1100-021	HP38 - Filter Mounting Bracket	42	6	09-100	1/4" Lock Washer
13	1	1100-020	HP38 - Engine Mount Plate	43	1	03-1103	Tiny Tach (HP-38)
14	1	14-2049	16 Gallon Fuel Tank (HP-38)	44	1	03-1002	7565 Battery
15	1	14-123	Kohler ECH980	* 45	1	03-866	Rocker Switch (HP-38)
16	4	09-418	5/8" Hitch Pin Assembly	46	1	03-804	B080804CH Piano Hinge Box
17	4	09-375	5/16" -18 x 3-1/2" GR5 Bolt	47	1	03-759	40HP 3PH 1800RPM 575V 324TC
18	2	09-364	1/4-20 x 3 1/2 GR5 Bolt	48	4	02-806	3/8-16 Vibration Mount
19	40	09-342	5/16-18 x 1" GR5 Bolt	49	1	02-6085	Electric/Hydr Control Valve (HP-38)
20	8	09-322	1/4-20 x 3/4" GR5 Bolt	50	1	02-4007	BMK6-630 Hydraulic Motor
21	1	03-767	Thermal Transfer 12V Oil Cooler (HP-38)	51	1	02-359	Panel Mount gage 63MM U-Clamp Kit
22	8	09-3197	5/16-18 x 1 1/4 GR8 Bolt	52	1	02-358	Hydraulic Oil Tank (HP-38)
23	1	02-286	1 1/4" JICM to 1" ORBM 45° Adapter	53	1	02-357	2-1/2 Panel Gauge 0-1000 1/4NPT (HP-38)
24	8	09-317	1/2-13 x 1 1/2" GR5 Bolt	54	1	02-356	Hydraulic Filter (HP-38)
25	6	09-310	3/8-16 x 1 1/4" GR5 Bolt	55	1	02-355	Filter Head (HP-38)
26	4	09-308	3/8-16 x 1 1/2" GR5 Bolt	56	1	67670	Manual Canister 12"
* 27	4	09-307	3/8-16 x 1" GR5 Bolt	57	4	92865A537	1/4-20 x 1/2 Hex Head Screw
28	2	09-305	5/16-18 x 2" GR5 Bolt	58	2	92825A205	LDPE Unthrded Spcr, 3/4" OD x 1" Lg
29	2	09-301	1/4-20 x 1" GR5 All Thread Bolt	* 59	2	90604A272	10-32 x 1 Pan Head Screw SS
30	2	09-276	10-32 Nylon Flange Locknut	60	4	09-3230	1/2"-13 x 1-3/4" SHCS
				61	4	09-122	1/2" Wedge Lock Washer

\* Items Shown Are Optional

## HP38SM / HP38 ASSEMBLY PARTS LIST

PARTS LIST			
ITEM	QTY	PART NUMBER	DESCRIPTION
1	1	1100-A-28	Negative Battery Cable
2	1	1100-A-27	Positive Battery Cable
3	2	14-2059	Spark Plug (CH980)
4	1	1100-512	1/4 ID Low Pressure Fuel Hose 48"
5	1	1100-513	3/16 Fuel Injection Hose 48"
6	1	14-2058	Oil Filter Kohler (CH980)
7	1	14-2057	Pre-Cleaner Filter Kohler (CH980)
8	1	14-2056	Primary Air Filter Element Kohler (CH980)
9	1	14-2055	Fuel Filter Kohler (CH980-3000)
10	1	14-2049	16 Gallon Fuel Tank (HP-38)
11	1	14-2044	Kohler ECH980 Muffler
12	1	14-2042	8 Gallon EPA Fuel Tank Assembly
13	1	14-123	38HP EFI Kohler Engine
14	4	12-118	1/4"- 5/8" Hose Clamp
15	1	03-1025	HP-20 Positive Battery Lug
16	1	03-1024	HP-20 Negative Battery Lug
17	1	03-1002	7565 Battery
18	1	02-561	Gear Pump (HP-38)
19	1	02-562	Pump Adapter (HP-38)
20	1	15-136	L110-7/8 HUB 1/4 Key Lovejoy Coupling
21	1	15-1017	L110 Spider (HP-38)
22	1	15-1018	L110 x 7/16 x 3/8 Coupling (HP-38)

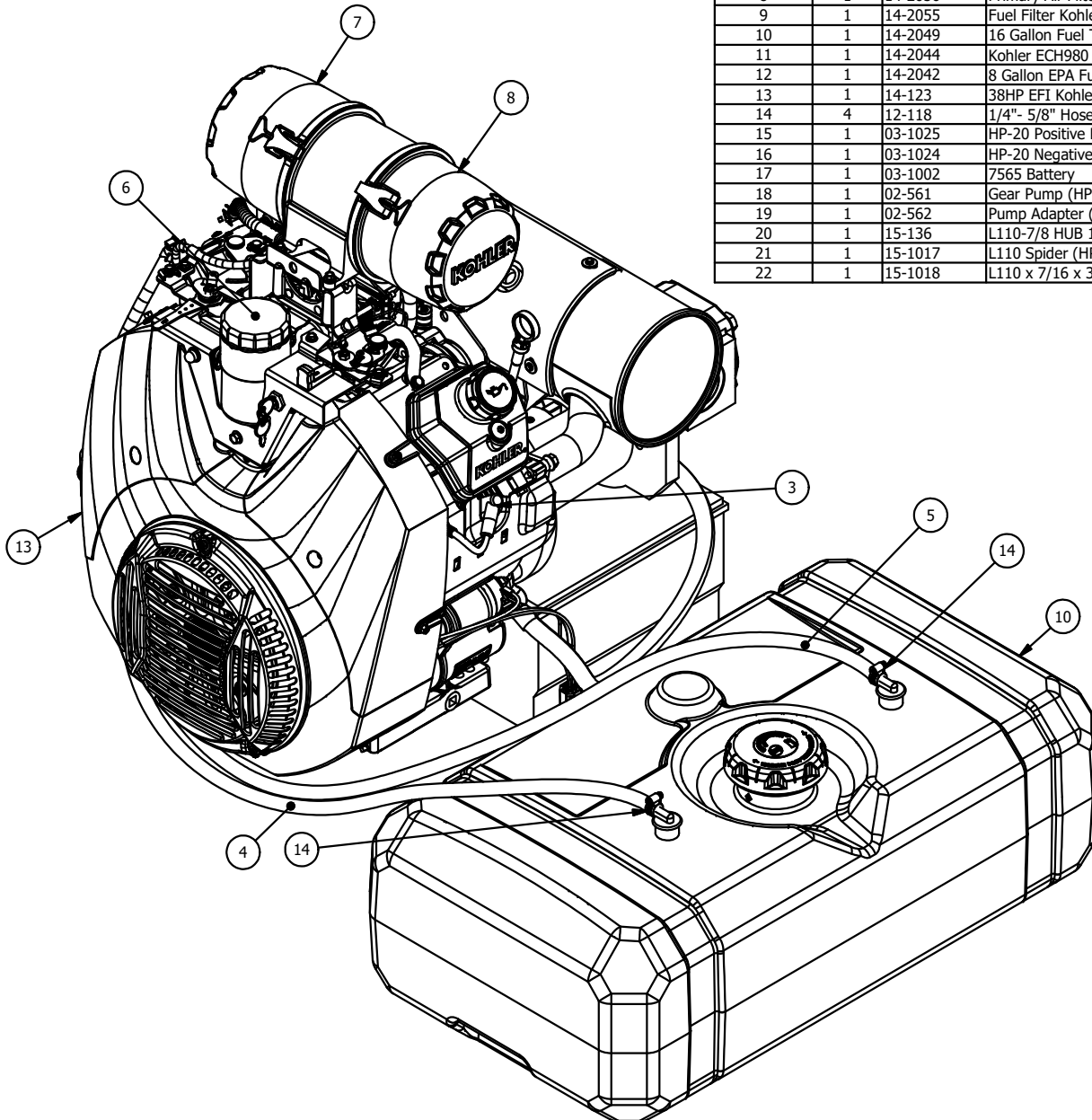

## KOHLER ECH980 ENGINE

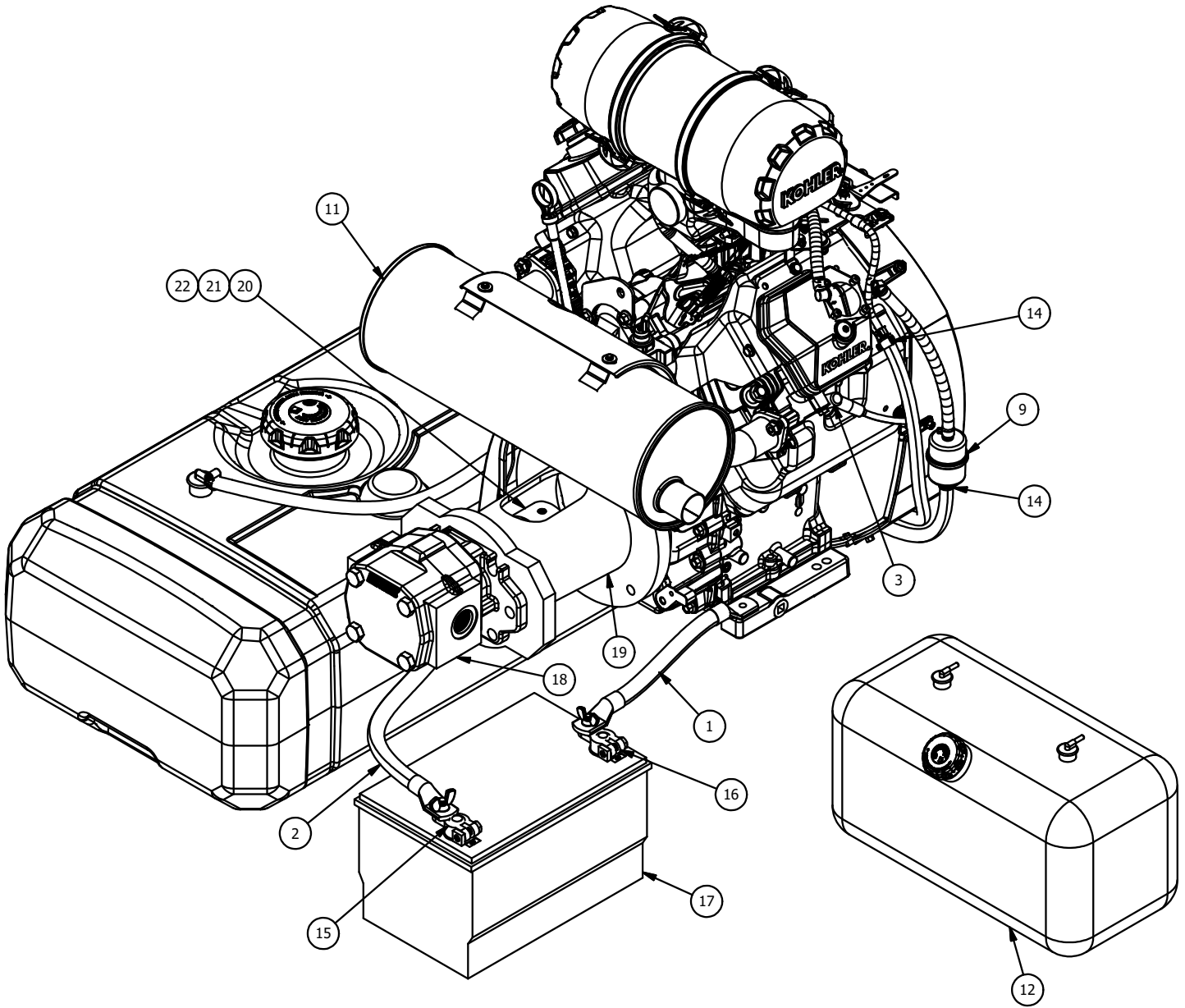

## KOHLER ECH980 ENGINE

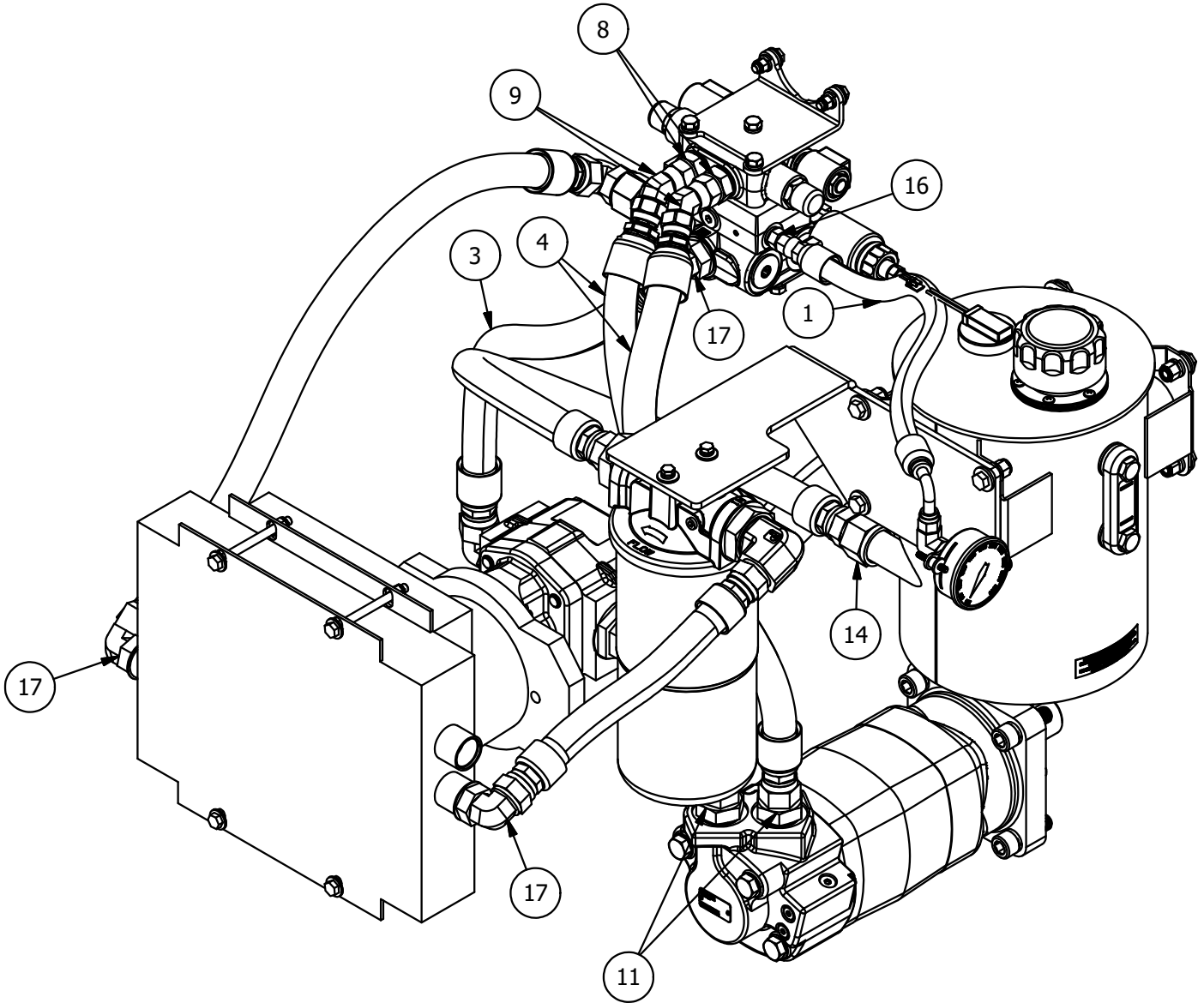

## HP38SM / HP38 HYDRAULIC ASSEMBLY



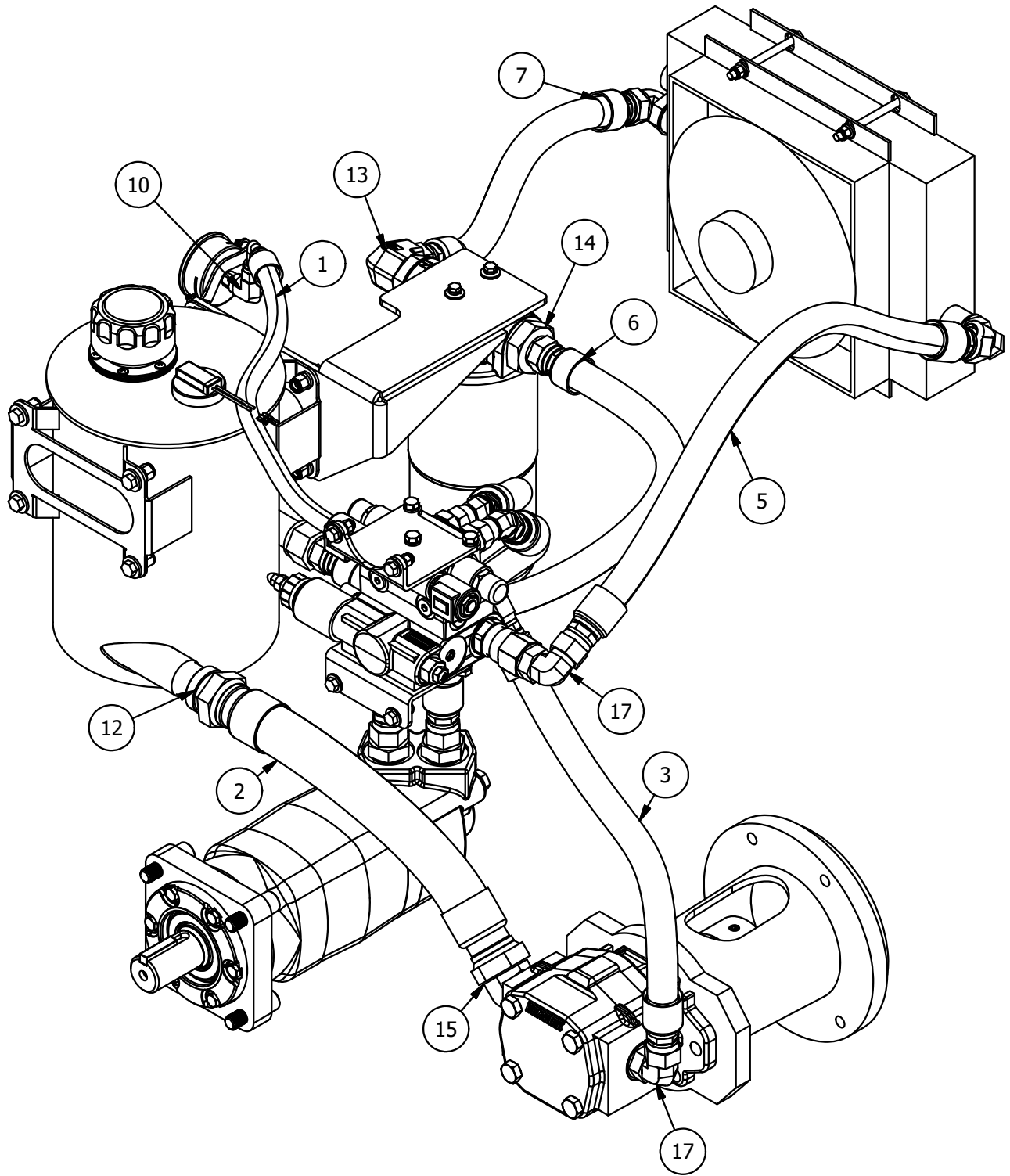

## HP38SM / HP38 HYDRAULIC ASSEMBLY

**PARTS LIST**

ITEM	QTY	PART NUMBER	DESCRIPTION
1	1	1100-A-11	HP38 - Hose Assy-Pressure Gage to Valve
2	1	1100-A-12	HP38 - Hose Assy-Cyclone OUT to Pump IN
3	1	1100-A-13	HP38-Hose-Pump OUT to Valve IN
4	2	1100-A-14	HP38-Hose-Valve A-Motor A & ValveB-MotoB
5	1	1100-A-15	HP38-Hose-Valve OUT-Heat Exchanger Top
6	1	1100-A-16	HP38-Hose Assy-Filter OUT-Cyclone Return
7	1	1100-A-17	HP38-Hose Assy-HE Bottom to Filter IN
8	2	02-2174	5/8 MJIC x 5/8 MORB Straight Connector
9	2	02-2172	5/8 MJ x 5/8 FJX 45 Degree Swivel Elbow
10	1	02-2161	3/8"JICM x 1/4" NPTF 90° - Elbow
11	2	02-2160	3/4 JICM x 1" ORBM Straight Adapter
12	1	02-2159	1-1/2" JICF x 1-1/4" JICM Tube Reducer
13	1	02-2157	3/4 JICM x 1-1/4 ORBM 90 Deg Adapter
14	2	02-2018	1 JIC to 3/4 JIC Tube Reducer
15	1	02-286	1-1/4" JICM to 1" ORBM 45° Adapter
16	1	02-275	3/8" JICM to 3/8" ORBM Straight Adapter
17	5	02-201	3/4 JICM to 3/4 ORM 90 Adapter

**HP38SM / HP38 HYDRAULIC ASSEMBLY PARTS LIST**

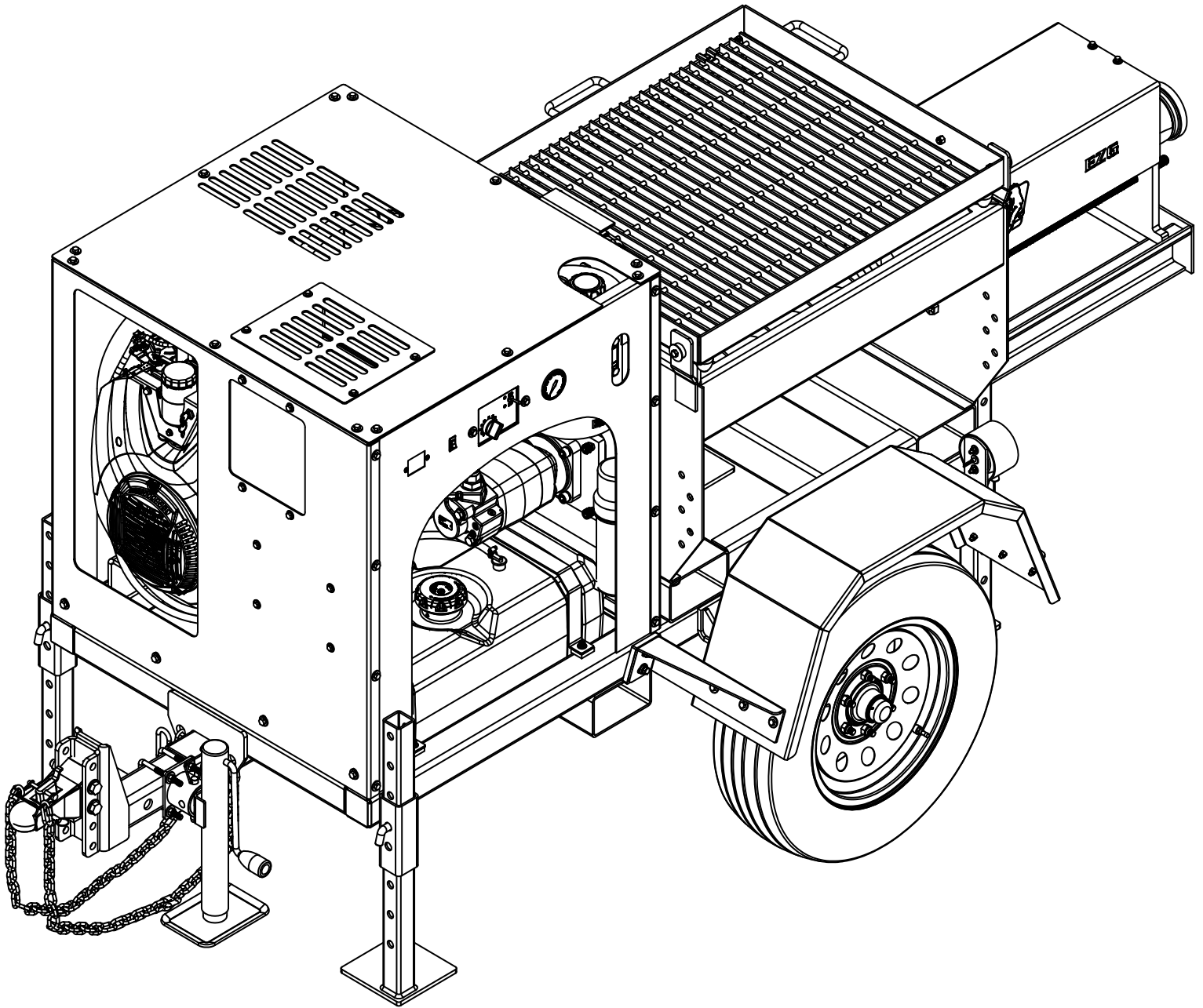

## HP38 TRAILER MOUNTED

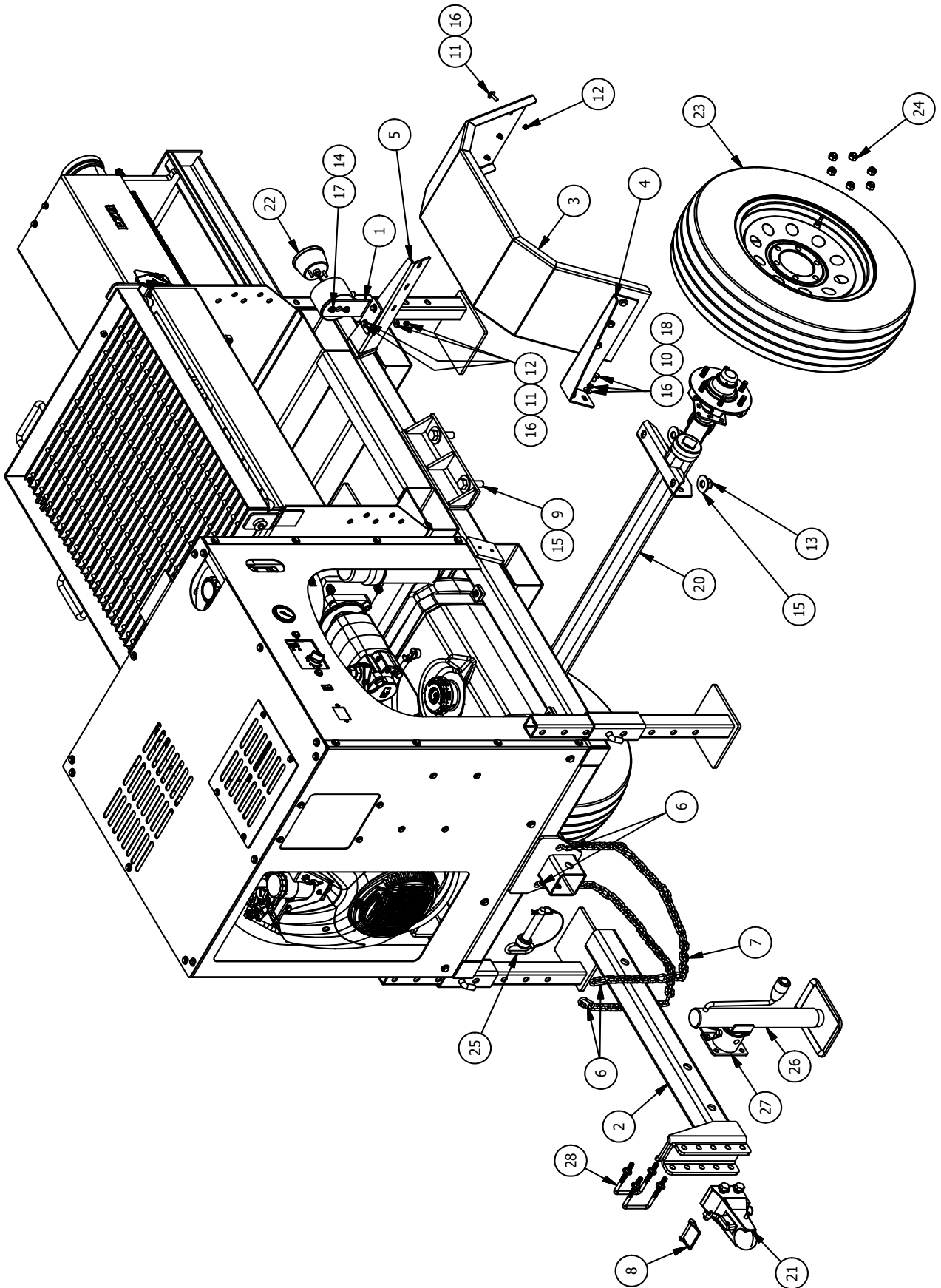

# HP38 ASSEMBLY

PARTS LIST			
ITEM	QTY	PART NUMBER	DESCRIPTION
1	2	1100-A-07	HP38 - Taillight Welded Assembly (1)
2	1	901-A-5	X1000 Tongue Welded Assembly
3	2	1000-111	HP-20T4 - Steel Fender (10 Gauge)
4	2	900-007L	Graber Fender Mount
5	2	900-007R	Graber Fender Mount
6	4	09-701	Connecting Link
7	2	09-700	1/4" Proof Coil Plated Chain
8	1	09-407	5/16" Latch Pin
9	4	09-333	3/4-10 x 2 1/2" GR8 Bolts
10	8	09-355	3/8-16 x 3/4" GR5 Bolt
11	16	09-342	5/16-18 x 1" GR5 Bolt
12	18	09-202	5/16"-18 Nylon Nut
13	4	09-236	3/4-10 GR8 Nylon Nut
14	4	09-200	1/4"-20 Nylon Nut
15	8	09-128	3/4 GR8 Flat Washer
16	26	09-105	5/16" Flat Washer
17	4	09-104	1/4" Flat Washer
18	8	09-102	3/8" Lock Washer
19	4	09-101	5/16" Lock Washer
20	1	07-181	MDI X1000 Axle 3500# No Brake
21	1	07-168	MDI 2 5/16 Channel Style Coupler
22	2	07-151	EZL Tail Light
23	2	07-149	Radial Tire/Wheel 15" Silver Mod.
24	12	07-134	EZG Lug Nut
25	1	91594A335	7/8 x 4 Clevis Pin
26	1	07-183	Pipe Mount Jack 2K
27	1	901-033	X1000 Jack Pipe Mount Plate
28	2	09-3204	4 5/8 x 3 U-Bolt (X1000)

## PARTS LIST

