

# Hog Guard®

## Scaffold Safety Accessories

The Hog Guard is designed to block off openings that occur on scaffolding assemblies such as, door frames, window allowances or any large opening that may present a potential fall risk associated with typical masonry and block jobs.

When using the Hog Guard components with your scaffolding, the uprights are to be positioned in the space of the opening allowance, hooking securely onto the walk boards. Once the end guard and rail assembly are in place there are slots at the top, bottom, and middle to insert 2x4's that will act as the guard rails thus preventing workers from falling through an opening.

### Hog Guard Features:

- Inter-changeable components are sold separately to custom fit your site needs for added safety.
- Ready-fit design for simple assembly and break down.
- Made to work with most existing scaffold systems.



Assembly using standard scaffolding features all three accessory components.

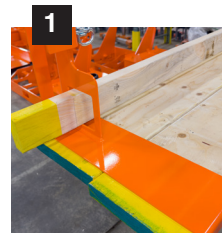

**Center Rail Assembly** hooks securely to walk boards



Slots on the **Center Rail Assembly** easily accommodate 2x4's



**Stocking-Bracket** can be added, providing convenient access to block or tools

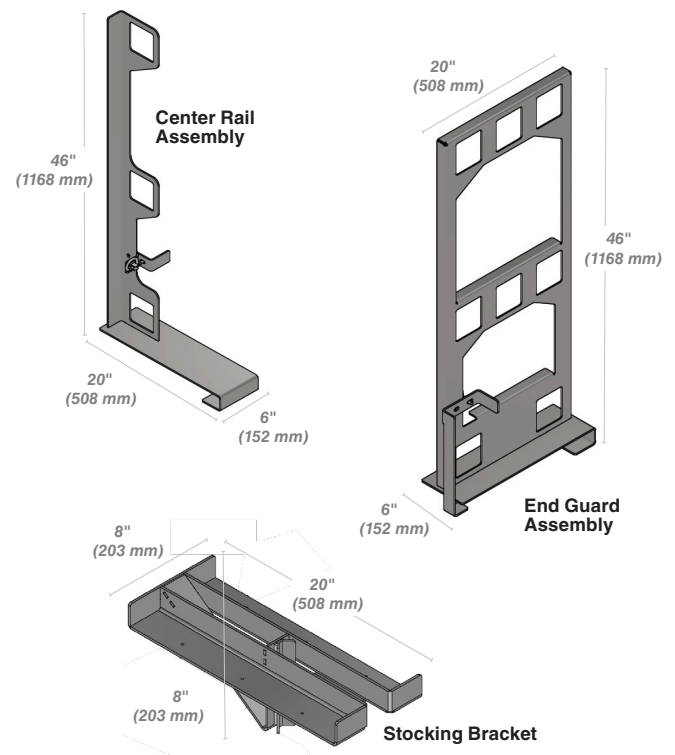
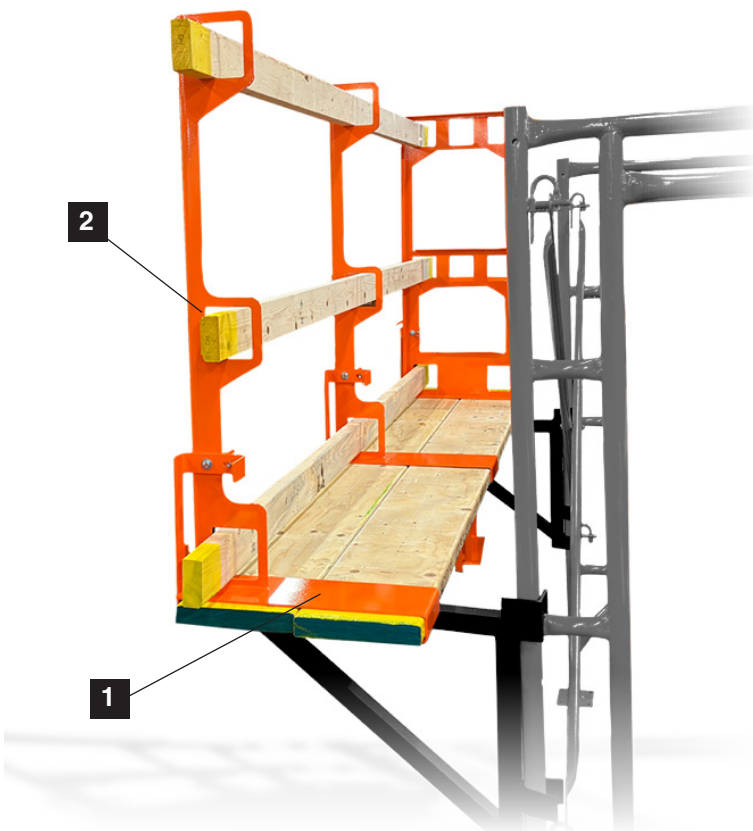

**Increase efficiency, profitability and safety on the job.**

## Part HGS-A-1

End Guard Assembly

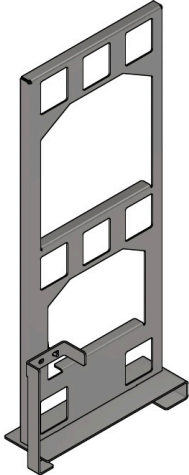

## Part HGS-A-2

Center Rail Assembly

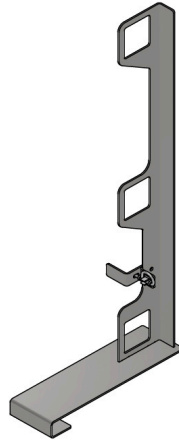

## Part HGS-A-3

Stocking Bracket

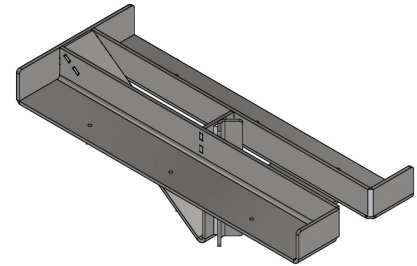

### Hog Guard® Component Specifications

MODEL	HGS-A-1	HGS-A-2	HGS-A-3
Overall Dimensions: (L x W x H)	20" x 6" x 46" (508 x 152 x 1168 mm)	20" x 6" x 46" (508 x 152 x 1168 mm)	20" x 8" x 8" (508 x 203 x 203 mm)
Steel	1/4 in. (base plate) 10 gauge. (vertical)	1/4 in. (base plate) 3/16 in. (vertical)	1/4 in. (base plate) 1/4 in. (vertical)
Weight	31 lbs (14 kg)	24 lbs (11 kg)	16 lbs (7 kg)

   **Love it? We want to hear from you.**

Snap a photo or capture a video of your team putting any of our Hog Guard System to use and post it. Remember to tag us @EZG and use #leanmasonry, in your post.

... Thank you for your continued commitment to the EZG product line.



1-800-417-9272 / [ezgmfg.com](http://ezgmfg.com) / [sales@ezgmfg.com](mailto:sales@ezgmfg.com)  
1833 N. Riverview Road, Malta, Ohio 43758

EZG Manufacturing is a division of EZ Grout Corporation. All EZG Manufacturing products are backed by our **two-year warranty** on parts unless otherwise stated and are available for order direct through our website.

