

**BUILT TO
WITHSTAND
THE TOUGHEST
JOBS.**



EZG[®]
Manufacturing



MASONRY / CONSTRUCTION

ABOUT US

THE BEGINNING OF EZG

EZG Manufacturing started as EZ Grout and was born from the desire of one man to improve the quality of equipment used in masonry. In 1998, founder and CEO Damian Lang sought to help contractors increase efficiency and profitability with American made products built from hands-on experience. Masonry equipment available at the time lacked sturdiness and reliability, causing operators to experience systemic machine clogs and mechanical failures. Damian developed the first Grout Hog® after numerous prototypes. Over time, he perfected models by patenting new features specific only to the EZ Grout line, like clog-prevention mechanisms and an innovative delivery system.

SUCCESSFUL EXPANSION

Once Damian's invention proved useful, he turned his creative focus to other areas of construction and masonry, eventually releasing the Mud Hog®, Uphill Grout Hog®, Hog Slopper®, Hog Leg®, Hog Trough® and Booger Hog®. In the early 2000's Damian introduced his Fence Hog® which now includes several models for the fencing industry. This automated fence installation equipment is well-known for saving construction crews hundreds of hours on large projects on virtually any terrain.

EZG MANUFACTURING

EZG's reputation as an industry leader in masonry, fencing, and construction markets grew and soon its products were found on construction sites all over the globe. As Damian and his team learned more about the industry, they began to develop custom solutions for specific contracting problems. This led to the formation of EZG Manufacturing, which offers an extensive range of services including, laser cutting, machining, and powder coat painting.

EZG TODAY

Damian continues to expand EZG's services and is quickly becoming a leading industry voice. As an author Damian also shares what he's learned after a lifetime of experience in his book R.A.C.E. - Rewarding and Challenging Employees: For Profits in Masonry. Damian's column, "[*Contractor Tip of the Month*](#)," can be found as a feature in multiple major industry magazines. He also regularly offers seminars and consultations for masonry and construction organizations all over the country.



Damian Lang
CEO - EZG Manufacturing



TABLE OF CONTENTS

Mixing 4–13

Mud Hogs.....	5	[jump to]
Mobile Mud Hogs.....	8	[jump to]
Mobile Mud Hog Trench Mixer.....	10	[jump to]
EZG Mixers.....	11	[jump to]

Delivery & Handling 14–23

Grout Hogs.....	15	[jump to]
Hog Pump.....	18	[jump to]
Mortar Hog.....	20	[jump to]
Hog Troughs (Steel).....	21	[jump to]
Hog Troughs (Poly).....	22	[jump to]
Hog Cart.....	23	[jump to]
Hog Slopper.....	23	[jump to]
Hog Trainer.....	23	

Wall Bracing..... 24–26

Hog Legs.....	25	[jump to]
---------------	----	-----------------------------

Job-site Tools & Products 27–35

Hogtrax Ground Protection.....	28	[jump to]
EZG Outrigger Pad.....	29	[jump to]
Hog Crusher.....	30	[jump to]
Krack Hog.....	31	[jump to]
Hog Guard.....	32	[jump to]
Hoist Hogs.....	33	[jump to]
Hog Waller / Booger Hog.....	34	[jump to]



[Grout Hogs...pg 15](#)

Mixers



Mud Hog®

Model MH9

- 2 to 3 bag capacity or 9 cu.ft. (.25 m³)
- Will mix up to 3/4" (19 mm) aggregate
- Hydraulic drive, hydraulic dump
- GX270 8 hp Honda® engine (optional electric motor)
- Unique paddle design consists of four reversible mixing paddles to decrease batch time; one-year warranty on rubber blades
- Adjustable height - loads below waist high enough to load into a wheelbarrow or mud tub
- Highway tires and torsion axle for smoother suspension; tow package is designed to pull from the side so that wheels are out of the way of wheelbarrow or the forks on a forklift
- Easier to back into sand pile
- Optional brake and light kit



[[view online](#)]

Model MH12

- 3 to 4 bag capacity or 12 cu.ft. (.34 m³)
- Will mix up to 3/4" (19 mm) aggregate
- Hydraulic drive, hydraulic dump
- GX390 11.7 hp Honda® engine with electric start (optional diesel engine or electric motor available)
- Fork pockets accessible from all four sides
- Unique paddle design consists of four reversible mixing paddles to decrease batch time; one-year warranty on rubber blades
- Adjustable height - loads below waist for reduced fatigue and can be raised to dump directly into a Grout Hog



[[view online](#)]

Model MH20

- 6 to 7 bags or 20 cu.ft. (.57 m³)
- Will mix up to 3/4" (19 mm) aggregate
- Hydraulic drive, hydraulic dump
- 5/16" thick steel rolled drum and 3/8" thick steel drum ends
- GX390 11.7 hp Honda® engine with electric start (optional diesel engine or electric motor available)
- Fork pockets accessible on all four sides
- Compacts to fit in standard 8 ft. (2.44 m) truck bed
- Unique paddle design consists of six reversible mixing paddles to decrease batch time; one-year warranty on rubber blades
- Adjustable height - loads below waist for reduced fatigue and can be raised to dump directly into a Grout Hog.



[[view online](#)]

Mud Hog Specifications:

MODEL	MH9	MH12	MH20
Capacity - cu.ft. (m³)	9 (.25)	12 (.34)	20 (.57)
Capacity - Bags*	2 to 3	3 to 4	6 to 7
Power Source	Honda GX270 8.5 hp (6.3 kw)	Honda GX390 11.7 hp (8.7 kw)	Honda GX390 11.7 hp (8.7 kw)
Engine Starting	Manual Recoil	Recoil/Electric	Recoil/Electric
Max Aggregate Size in. (mm)	3/4 (19)	3/4 (19)	3/4 (19)
Drum Thickness in.	1/4	End 3/8; Wrap 1/4	End 3/8; Wrap 5/16
Forklift Pockets	Optional	Standard	Standard
Axle Kit	Standard	Optional	N/A
Dimensions L x W x H in. (mm)	81 x 35 x 54 (2057 x 889 x 1372)	82 x 42 x 49 (2082 x 1067 x 1245)	96 x 56 x 51 (2438 x 1422 x 1295)
Adjustable Discharge Height in. (mm)	Up to 26 (660)	Up to 49 (1245)	Up to 51 (1295)
Drive System	Hydraulic	Hydraulic	Hydraulic
Dump Action	Hydraulic	Hydraulic	Hydraulic
Empty Weight lb. (kg)	1400 (635)	1677 (761)	2278 (1033)

* Based on 80lb. pre-mix bags

MODEL	Description
MH9LIGHTKIT	Tail Light Kit, Model MH9
MHLIGHTKIT	Tail Light Kit, Model MH12
HMH-A-1	High Rise Conversion Kit, MH12

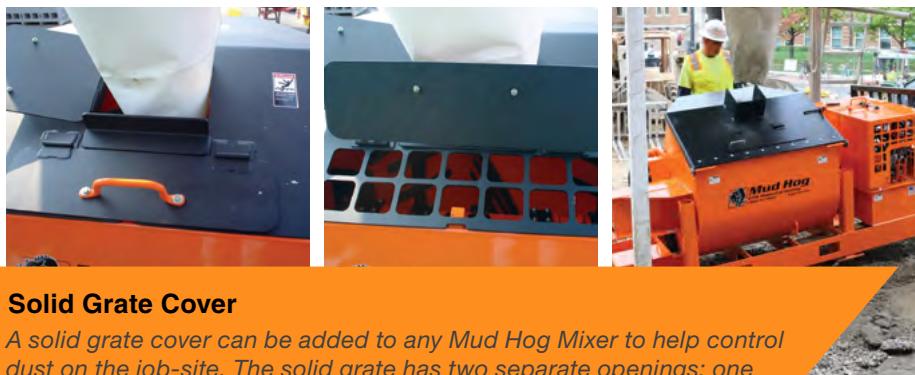

Solid Grate Cover

A solid grate cover can be added to any Mud Hog Mixer to help control dust on the job-site. The solid grate has two separate openings; one for adding mix, the other for water intake.



– Loads below the waist.



– Dumps high; directly into Grout Hog.

CUSTOMER REVIEWS

Mud Hog®



Dale Kartman, Specialized Equipment Rentals

“We purchased our first EZG Mud Hog mixer, a MH20, in 2007. Since that time we have purchased six more MH20’s. We like to invest in equipment that is going to last and after test driving the MH20, we were convinced that the Mud Hog Mixer was robust and was built to last. Everything about the EZG Mud Hog mixers has been well designed from the tub seals, paddle rubbers down to the bearings/sprockets and any repairs are fast and easy. And if you have a suggestion on changing something that might improve their product they are always willing to listen! This day and age you don’t find that too much in the industry anymore, I guess that’s why Specialized Equipment Rentals has a total of 63 pieces of EZG mixers and Grout Hogs *in our fleet.*”

Mackie Bounds, Brazos Masonry

“There is no doubt in my mind that the Mud Hog mixers are the best mixers we have ever used. After purchasing two mixers from EZG and putting these to test in the field, I plan on changing my entire fleet of mixers to the Mud Hogs.”

Paul M. Cantarella, Cantarella & Son, Inc.

“By far this is the best mixer on the Market. From the ease of maintenance to the safety of the labor mixing the Mortar, it is amazing. Every aspect of the machine was carefully thought out to make mixing as easy as possible. From the new enclosed lids to keep the dust down to a tool box for storage, they have everything perfectly placed. They are always trying to improve their products. I have been in the industry since I was 8 or 9 driving to job-sites and seeing our mixers on the job. With 30 years’ experience in this field I can confidently say hands down this is the best Masonry Mixer ever made PERIOD.”



Mobile Mud Hog®

The Mobile Mud Hog mixer provides the mix-on-demand utility that minimizes waste and maximizes productivity. Unloading exactly where concrete, grout, or mortar are needed eliminates unnecessary steps and saves time.

EZG Mobile Mud Hog brings accessible triple-use mixing to even the most difficult terrain. With all-sides accessible fork pockets, Mobile Mud Hog transport is a breeze with your forklift or skid steer and is equipped with hookups for auxiliary hydraulic power, so you always have access to a convenient power source. If no external power is available, Mobile Mud Hogs pack a powerful Honda® gas engine for additional flexibility.

If you need options, Mobile Mud Hog features a flexible product line up with four different models to serve your specialized needs. Whether you need high-capacity mixing, flexible power, powered dump gates or compact-operation, Mud Hog has an option that fits your needs.



[\[+ view online \]](#)



[\[+ view online \]](#)

Features:

- Mixing capacities range from 4 cu.ft. - 20 cu.ft. (.11 - .57 m³)
- Standard auxiliary hydraulic power source
- Options include extended dump chute, water bar and 11.7 hp (8.7 kw) Honda® gas engine
- Made in the USA

[\[view online \]](#)



[\[view online \]](#)

Mobile Mud Hog Specifications:

MODEL	MMH4	MMH9	MMH12	MMH20
Capacity	4 cu.ft. (.2 m ³)	9 cu.ft. (.25 m ³)	12 cu.ft. (.34 m ³)	20 cu.ft. (.57 m ³)
Capacity - Bags*	3 to 4	8 to 9	11 to 14	19 to 20
Power Source	Auxiliary Hydraulics	Auxiliary Hydraulics	Auxiliary Hydraulics	Auxiliary Hydraulics
Min. Hydraulic Flow	4 gpm @ 2000 PSI	4 gpm @ 2000 PSI	10 gpm @ 2400 PSI	10 gpm @ 2400 PSI
Max. Hydraulic Flow	16 gpm @ 3000 PSI	26 gpm @ 3000 PSI	40 gpm @ 3000 PSI	40 gpm @ 3000 PSI
Drum Thickness in. (mm)	3/16" (5 mm)	1/4" (6 mm)	1/4" (6 mm)	3/8" (9.5 mm) w/ 5/16" (8 mm) drum wrap
Forklift Pockets	Standard	Standard	Standard	Standard
Dump Action	Manual Gate	Manual Gate	Hydraulic Gate	Hydraulic Gate
Material Discharge	1/2 yd. ³ /min.	1/2 yd. ³ /min.	1/2 yd. ³ /min.	1/2 yd. ³ /min.
Drive System	Hydraulic	Hydraulic	Hydraulic	Hydraulic
Dimensions L x W x H in. (mm)	29" x 44" x 29" (737 x 1118 x 736)	55" x 33"x 42" (1397 x 838 x 1067)	72" x 40" x 52" (1829 x 1016 x 1321)	82" x 45" x 56" (2083 x 1143 x 1422)
Weight lbs. (kg)	482 (219)	750 (340)	925 (420)	1350 (612)

* Based on 80lb. pre-mix bags

Mobile Mud Hog® Trench Mixer

An efficient solution for precision pour applications. Whether for micro-trenching in tight spaces or utility work, this hydraulic-controlled mixer suits walk-behind and standard/full-sized skid steers.

Operational simplicity is key—add water and materials, start the paddle rotation, and drive the skid steer along the trench line. The gravity-fed system with a hydraulic release gate ensures controlled material flow to the 1 1/2" chute opening. The Mobile Mud Hog Trench Mixer, with hydraulic power, is a must-have for contractors prioritizing efficiency on-site.

Features:

- Sturdy integrated lifting pockets for transporting and skid steer attachment plate come standard.
- Mixing bin accommodates 9 cu.ft. or 1/3 yd. of material (8-9 80 lb. premix bags).
- Patented rubber blades facilitate optimal mixing.
- Hydraulic controlled release gate.
- Comes standard with choice of universal or walk-behind skid steer backing plate



[\[+ view online \]](#)



SPECIFICATIONS	MMH9-MICRO-TRENCH
Dimensions L x W x H (mm)	61" x 33" x 42" (1,549 x 838 x 1,067 mm)
Trencher Plate L x W (mm)	12" x 6" (305 x 154 mm)
Trencher Opening L x W (mm)	8" x 1.5" (203 x 38 mm)
Weight— empty	700 (318 kg)
Capacity	9 cu.ft. (0.25 m ³) approx 8-9 bags*
Min. Hydraulic Flow	4 gpm @ 2,000 PSI
Max. Hydraulic Flow	26 gpm @ 3,000 PSI
Drum Thickness	1/4" (6 mm)
Forklift Pockets	Standard

* Based on 80lb. pre-mix bags

EZG® Mixer

Model EZG7

- 1 1/2 to 2 bag capacity or 5.6 cu.ft. (.16 m³)
- 7.9 hp Honda® Gas Engine (Standard)
- Will mix up to 3/4" (19 mm) aggregate
- Discharges up to 21" high without the use of blocking
- 48 in. load height
- Manual recoil start
- 3/16" drum thickness
- 4"x 6" rectangular structural tubing
- 1 1/4" solid steel shaft
- 2" ball hitch
- Pintle hitch available
- Optional leg kit
- Electric models available

[ [view online](#)]



Model EZG9

- 2 1/2 to 3 bag capacity or 9 cu.ft. (.25 m³)
- 7.9 hp Honda® Gas Engine (Standard)
- Will mix up to 3/4" (19 mm) aggregate
- Discharges up to 20 in. high without the use of blocking
- 56 in. load height
- Manual recoil start
- 3/16 in. drum thickness
- 4"x 6" rectangular structural tubing
- 1 3/4" solid steel shaft
- 2" ball hitch
- Optional leg kit
- Pintle hitch available
- Electric models available

[ [view online](#)]



Operator Convenience

The EZG mixers are easy to load and dump into Hog Troughs® or wheel barrow without having to be raised on blocks.

EZG® Mixer

Model EZG12

- 3 to 4 bag capacity or 12 cu.ft. (.34 m³)
- 11.7 hp Honda® Gas Engine (Standard)
- Will mix up to 3/4" (19 mm) aggregate
- Discharges up to 20" high without the use of blocking
- 56" load height
- Manual recoil start
- 1/4 in. drum thickness
- 4" x 7" rectangular structural tubing
- 1 3/4" solid steel shaft
- 2" ball hitch
- Pintle hitch available
- Electric models available
- Leg kit included

[view online](#)



EZG Mixer Specifications:

MODEL	EZG7	EZG9	EZG12
Capacity - cu.ft. (m³)	5.6 (.16)	9 (.25)	12 (.34)
Capacity - Bags*	1 1/2 to 2	2 to 3	3 to 4
Power Source* HP (kw)	Honda GX240 7.9 (5.6)	Honda GX240 7.9 (5.6)	Honda GX390 11.7 (8.7)
Engine Starting	Manual Recoil	Manual Recoil	Manual Recoil
Electric Motor - 1PH/115V hp	1.5	N/A	N/A
Electric Motor - 1PH/230V hp	N/A	5	10
Electric Motor - 3PH/230V hp	N/A	5	10
Electric Motor - 3PH/460V hp	N/A	5	10
Drum Thickness in.	3/16	3/16	1/4
Forklift Pockets	Standard	Standard	Standard
Discharge Height in. (mm)	22 (559)	20 (508)	20 (508)
Load Height in. (mm)	49 (1245)	56 (1422)	56 (1422)
Dump Action	Manual	Manual	Manual
Drive System	Chain	Chain	Chain
Dimensions	71 x 47 x 58 (1803 x 1194 x 1473)	70 x 47 x 63 (1778 x 1194 x 1600)	72 x 49 x 66 (1829 x 1245 x 1676)
L x W x H in. (mm)	104 L w/tongue (2542) 70 H w/dump handle (1778)	107 L w/tongue (2718) 77 H w/dump handle (1956)	110 L w/tongue (2794) 77 H w/dump handle (1956)
Weight lb. (kg)	760 (345)	865 (392)	1195 (542)

* Based on 80lb. pre-mix bags

CUSTOMER REVIEWS

EZG® Mixer ★★★★★

Rob Roussel, Robert's Masonry

“Being a smaller Mason contractor, we needed a mixer we could count on. Yes, there were cheaper mixers on the market but we needed a mixer that would stay out in the field and out of the shop. We have been using both EZG’s manual and hydraulic mixers for over 4 years and plan on adding more to our fleet when needed. Their uphill grout hog is amazing. We watch our competition who are still in the stone age using buckets and tubs to grout and are so happy we have EZG’s Grout Hog. The customer service at EZG is also fantastic.”

Delivery & Handling



Grout Hog®

Model GPHC75

- Built for use with crane or forklift
- Will deliver up to 3/4" aggregate (19 mm)
- Unloads 3/4 cu.yd. (.57 m³) in approx. 2 1/2 minutes
- GX390 11.7 hp Honda engine with electric start (optional diesel engine or electric motor available)
- Unique swivel-base system allows workers to reach 17 ft. (5.2 m) of wall quickly without moving forklift
- 8 ft. (2.44 m) reinforced, collapsible dispensing hose (standard)
- Removable auger allows for 15 minute clean up
- Hydraulic shut off allows for easy control of high slump or SCC concrete



[[view online](#)]

Model GH75

- Hooks to auxiliary hydraulics of forklift
- Will deliver up to 3/4" aggregate (19 mm)
- Unloads 3/4 cu.yd. (.57 m³) in approx. 2 1/2 minutes
- Delivers sand and dry materials
- Unique swivel-base system allows workers to reach 17 ft. (5.2 m) of wall quickly without moving forklift
- 8 ft. (2.44 m) reinforced, collapsible dispensing hose (standard)
- Removable auger allows for 15 minute clean up
- Hydraulic shut off allows for easy control of high slump or SCC concrete

[[view online](#)]



Model UGPH75

- Will deliver up to 1/2" (13 mm) aggregate
- Makes grouting from the scaffold side of the wall easier
- Unloads 3/4 cu.yd. (.57 m³) in approx. 2 1/2 minutes
- Removable auger and hopper tilt allows for 15 minute clean up
- Extended auger tube saves several feet of boom extension on your forklift
- Decreased head height allows pouring up close to bar joist on interior walls
- Unique swivel base allows grouting from all angles while eliminating extra forklift moves.
- 8 ft. (2.44 m) reinforced, collapsible dispensing hose standard
- Pendant cable control operation (forward and reverse); optional wireless remote



[[view online](#)]

Grout Hog Specifications:

MODEL	GH75	GPH75	GPHC75	UGH75	UGPH75	UGPHC75
Machine Type	Horizontal Auger	Horizontal Auger	Horizontal Auger	Uphill Auger	Uphill Auger	Uphill Auger
Lifting Bale	N/A	N/A	Standard	N/A	N/A	Standard
Capacity cu.yd. (m ³)	3/4 (0.57)	3/4 (0.57)	3/4 (0.57)	3/4 (0.57)	3/4 (0.57)	3/4 (0.57)
Material Discharge	3/4 cu.yd. 2.5 minutes	3/4 cu.yd. 2.5 minutes	3/4 cu.yd. 2.5 minutes	3/4 cu.yd. 2.5 minutes	3/4 cu.yd. 2.5 minutes	3/4 cu.yd. 2.5 minutes
Power Source	Auxiliary	Honda GX390 11.7 hp (8.7 kw)	Honda GX390 11.7 hp (8.7 kw)	Auxiliary	Honda GX390 11.7 hp (8.7 kw)	Honda GX390 11.7 hp (8.7 kw)
Aggregate Size in. (mm)	3/4 (19)	3/4 (19)	3/4 (19)	1/2 (13)	1/2 (13)	1/2 (13)
Hyd. Flow Rate gpm@2000psi	10	10	10	10	10	10
Empty Weight lb. (kg)	990 (449)	1429 (648)	1534 (696)	1055 (478.5)	1472 (668)	1565 (709.8)
Gross Weight lb. (kg)	4010 (1819)	4436 (2012)	4525 (2053)	4055 (1839)	4475 (2030)	4565 (2071)
Dimensions L x W x H in. (mm)	91 x 41 x 48 (2311 x 1041 x 1219)	91 x 41 x 48 (2311 x 1041 x 1219)	91 x 41 x 66 (2311 x 1041 x 1676)	113 x 47 x 48 (2870 x 1194 x 1219)	113 x 47 x 48 (2870 x 1194 x 1219)	113 x 47 x 63 (2870 x 1194 x 1219)

[ [view online](#)]



Wireless Remote

A wireless remote option is available on gas powered units.



— Grout Hog crane bale system in use.

CUSTOMER REVIEWS

Grout Hog® ★★★★★

Bob Schroeder, Jensen Masonry

“The Grout Hog saves us time and money when it comes to grouting the walls. Our foremen on two different job-sites were fighting over the Grout Hog we own. We should own more, they work like a champ. You can grout up to 8 yards of core fill in under 45 minutes under ideal working conditions.”

Geno Virgili, Mardo Masonry

“The Grout Hog is uniquely designed and an efficient means of installing grout regardless if 'Low Lift' or 'High Lift' grouting methods are being utilized. When the amount of grout needing to be installed does not justify the use of a conventional standard line - Mobile grout pump. The Grout Hog is a time and money saver. In a very short period of time the Grout Hog pays for its initial cost with the efficient delivery of grout into the wall. (GREAT PRODUCT)!”

Tracy Kiser, Kiser Masonry

“Our company has three Grout Hog's that we work with. We purchased our first Grout Hog about 10 years ago and still use it on our job-sites. Our most recent purchase was the Uphill Grout Hog and it was definitely a great addition to our fleet. We can really tell the increase in production time when using these products.”

CUSTOMER REVIEWS

Hog Pump® ★★★★★

Curt Henderson, Market & Johnson

“The EZG Pump is the simplest and most user friendly pump we have found for grouting walls. From set-up to clean-up, it has been reliable and easy to use.”

Hog Pump®

Model HP-20T4

- Triple use: Mortar, Grout, and Concrete
- Plus 1 control system with a DP250 Digital display for diagnostic & monitoring
- Horizontal pumping distance 800 ft.; Vertical is 200 ft.
- Ideal for filling block walls with grout or pea gravel
- Delivers up to 18 cu.yd. per hour w/ 2" line
- Features an 8 cu.ft. hopper
- Handles up to 3/4" (19 mm) aggregate
- Powered by a 56 HP Kubota® Diesel DOC final tier 4 engine
- Full reversible S-Tube valve for increased ease and safety over “ball valve” designs
- Optional wireless remote
- Chromed material cylinder tubes



[\[🔍 view online\]](#)

HP-38 / 38SM / 38SS Features:

- Handles self-consolidating, 3/8" ready mix and light-weight concrete as well as masonry grout, pour & form; shotcrete and slurry.
- Progressive cavity pumping with variable speed hydraulics and reversible functionality
- Handles 3/8" (10 mm) pea gravel
- Features an 8 cu.ft. (225 L) hopper
- Delivers up to 12 cu.yd. (9.2 m³) per hour with a 2" (50 mm) line
- Diesel and electric power supply options



[\[view online \]](#)



[\[view online \]](#)



[\[view online \]](#)

Hog Pump® Specifications

MODEL	HP-20T4	HP-38	HP-38SM	HP-38SS
Overall Dimensions: L x W x H in. (mm)	162" x 72" x 44" (4115 x 1829 x 1118)	120" x 72" x 70" (3048 x 1829 x 1778)	110" x 60" x 50" (2794 x 1524 x 1270)	94" x 48" x 48" (2387 x 1219 x 1219)
Hopper Capacity cu.ft. (L)	8 cu.ft. (225)	8 cu.ft. (225)	8 cu.ft. (225)	8 cu.ft. (225)
Aggregate Size in. (mm)	3/4" (20)	3/8" (10)	3/8" (10)	3/8" (10)
Power Source	Kubota Diesel 59 hp (44 kw)	Kohler ECH980 38 hp (28 kw)	Kohler ECH980 38 hp (28 kw)	Auxiliary Hydraulic Powered up to 42 GPM @ 2,600 psi.
Axel Kit	standard	standard	--	--
Material Discharge/ (output line) in. (mm)	15 cu.yd. (11.5 m ³) / 2" (50)	10-12 cu.yd. (7.6 - 9.2 m ³) / 2" (50)	10-12 cu.yd. (7.6 - 9.2 m ³) / 2" (50)	8-10 cu.yd. (6.1 - 7.6 m ³) / 2" (50)
Wheels in. (mm)	15" (381)	15" (381)	--	--
Weight lbs. (kg)	3,200 lbs. (1452.5)	2,800 lbs. (1270.1)	2,000 lbs. (907.2)	1135 lbs. (514.8)

Mortar Hog®

Mortar Board

Introducing the newest addition to our Hog Line, the Mortar Hog. Designed and manufactured to the same industry-leading standard for quality and performance on the job that our entire masonry product line represents.

- Sturdy ergonomic design for easy handling and workability
- Beveled edge helps contain mortar reducing waste and site clean up
- Non-porous surface eliminates water absorption, preserving mortar consistency
- Resistant to breakage or splitting caused by prolonged exposure water, sun and extreme cold



[view online](#)

MODEL	MHB24HD*	MHB32x24	MHB30x30
Dimensions: L x W (mm)	24" x 24" (610 x 610)	24" x 32" (610 x 812)	30" x 30" (762 x 762)
Thickness in. (mm)	.39" (10)	.39" (10)	.39" (10)
Absorption	< 0.01%	< 0.01%	< 0.01%
Tensile Strength	4700 psi	4700 psi	4700 psi
Min. / Max. Temperature	-40°F / 180°F	-40°F / 180°F	-40°F / 180°F
Weight lbs. (kg)	8.2 lbs. (3.7)	11.0 lbs. (5.0)	13.2 lbs. (6.0)

* Our MHB24HD is also available with 2 handles (MHB24-2H).



Steel Hog Trough®

Model HTS10

- 10 cu.ft. capacity
- 10 gauge steel
- 170 lb. (78 kg)
- Forklift pocket access on all 4 sides
- (L x W x H) 54"x 24"x 23"

[ [view online](#)]



Model HTS10W

- 10 cu.ft. capacity
- 10 gauge steel
- 195 lb. (88 kg)
- Built in 1" channels allow for crane operation
- (L x W x H) 54"x 24"x 29"



[ [view online](#)]

Model HTS10C (not shown)

- 10 cu.ft. capacity
- 10 gauge steel
- 180 lb. (78 kg)
- Built in 1" channels allow for crane operation
- (L x W x H) 57"x 26"x 25"

Steel Hog Trough®

Model HT10 / HTW10

- 10 cu.ft. capacity
- 3/16" steel
- 255 lb. (116 kg)
- Built in 1" channels allow for crane operation
- (L x W x H) 57"x 29"x 23"
- Also available with 2 rigid and 2 swivel heavy duty casters
model HTW10: 330 lb. (150 kg) 60" x 25" x 30"



[view online](#)

Poly Hog Trough®

Model HTP10

- 10 cu.ft. (.28 m³) capacity
- Made of tough, nonstick polyethylene
- Resists dents or damage
- Can be cleaned in minutes
- Steel legs for use without pallets
- Lightweight, only 75 lb. (34 kg)
- Available in heavy duty polyethylene
- (L x W x H) 57"x 28"x 24"



[view online](#)

Model HTP10W

- 10 cu.ft. (.28 m³) capacity
- Made of tough, nonstick polyethylene
- Resists dents or damage
- Can be cleaned in minutes
- 90 lb. (41 kg)
- Available in heavy duty polyethylene
- 2 rigid and 2 swivel heavy duty casters
- (L x W x H) 57"x 28"x 29"



[view online](#)

Model HTP10C

- 10 cu.ft. (.28 m³) capacity
- Made of tough, nonstick polyethylene
- Resists dents or damage
- Can be cleaned in minutes
- 130 lb. (59 kg)
- Available in heavy duty polyethylene
- Includes bolt-in crane bale
- (L x W x H) 60"x 32"x 27"



[view online](#)

Hog Cart®

- Use to move brick, block or your Hog Trough*
- Built to withstand even the most rugged job-site
- Includes forklift pockets and safety brakes
- Wheels easily on scaffold and into your Hoist Hog
- Corner pockets allow 2" x 4" handles to be used

Model HC

- 275 lb. (125 kg)
- (L x W x H) 57"x 28"x 13"

Model HCBL

- 290 lb. (132 kg)
- (L x W x H) 48"x 48"x 12"
- Larger scale, designed to hold block



[[view online](#)]

Hog Slopper®

Features:

- Available with fork pockets or universal skid steer mount
- Adjustable from 6 3/4 cu.ft. (.19 m³) to 9 cu.ft. (.25 m³)
- Insures consistency of grout and mortar for improved production
- Improves batch time
- Helps avoid back strain
- Keeps sand pile away from mixer
- Weight for use with skid steer 260 lb. (118 kg)
- Dimensions for use with skid steer (L x W x H) 41" x 46" x 24"
- Weight for use with forklift 280 lb. (127 kg)
- Dimensions for use with forklift (L x W x H) 59" x 32" x 21"



[[view online](#)]

Hog Trainer®

Enhance your masonry training program with the Hog Trainer. The Hog Trainer reaffirms EZG's commitment to future masons and the masonry industry with a mobile and easy-to-setup bricklaying training station that makes end-of-session cleanup quick and painless.

- Overall dimensions without casters (L x W x H) 96" x 50" x 53 1/4"
- Adjustable height
- Optional locking casters on 8" dia. wheels for easy transport
- Accessory hooks for tool and mortar board storage



[[view online](#)]

Wall Brace



Hog Leg®

Features:

- Engineered wall brace system
- Easy way to brace masonry walls
- Galvanized or painted pipe available
- Works for any type of block
- Adjusts to any wall height
- Fastens through head joints (no cutting of block required or anchor bolts to purchase)
- Makes your job site safer and more productive
- Includes convenient lockable storage rack to store all materials; fits in 8 ft. (2.438 m) bed; avoids theft.
- Fork pockets accessible on all four sides
- Lightweight - heaviest piece weighs 38 lb. (17 kg)
- Total weight 3826 lb. (1735 kg)
- Container dimensions (L x W x H) 89" x 43" x 26"



[[view online](#)]



[[view online](#)]

Hog Leg Extension Kit

- Extension kit to brace higher and further with your existing Hog Legs
- Galvanized or powder coat painted pipe available
- Total kit weight 2399 lb. (1088 kg)
- Total kit dimensions (L x W x H) 169" x 34" x 22"
- Lockable storage container



[[view online](#)]

Swivel Adjustment

Optional swivel adjustment pipes allow for four inch adjustment in and out.



CUSTOMER REVIEWS

Hog Leg®



Rick Swanson, Swanson Masonry

“Hog Legs are the easiest wall bracing system out on the market. We have braced everything from 12 ft. high to 78 ft. high walls and have had absolutely zero problems. This system is so easy to use.”

Rick Thomas, Rick Thomas Masonry LLC.

“The speed and ease of erecting the wall bracing system is great. The Hog Leg System takes all the doubt away that you may have if you follow the instructions. We had a school project with 30 ft. tall and 8 in. wide block walls. One day the winds speed got up to 70 mph and the Hog Legs kept the walls from falling over. When the inspectors examined the wall for damage the next day, there were no cracks. I truly know the Hog Leg System is a great product. Even the storage container makes the Hog Legs easy to store and easy to pick up and take to the job. They are easy for anybody to put together. The Hog Leg System is simple, durable and very dependable.”

"Digger", Duffy Bros. Masonry

“The Hog Legs from EZG are worth their weight in gold! They are easy to use, safe and extremely lightweight.”

Job-site Tools & Products



EZG Hogtrax®

EZG ground protection mats specifically engineered for large equipment use on susceptible surfaces. EZG Hogtrax features a robust diamond cleat over a directional pleat dual-surface tread design for aggressive grip, while preventing ruts, and establishing stable pathways.

Features:

- Capable of supporting weights up to 120 tons* per mat.
- Four hand holds per mat for easy manual mobilization and positioning.
- High-density polyethylene material ensures resistance to rot, splintering, warping and breakage.
- Effortless multi-mat connectivity for assembling temporary roads or functional platforms.

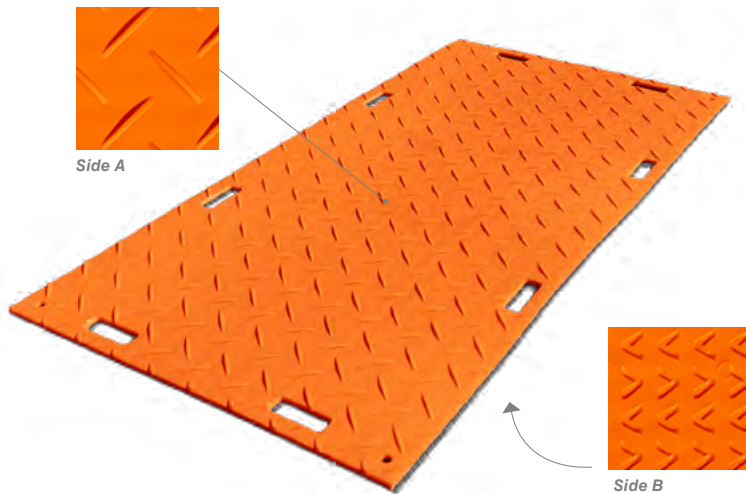

[[view online](#)]

GPM-SINGLE-CONNECTOR

Optional stainless steel connection clamps; item sold separately.



SPECIFICATIONS	GPM4x8 / GPM3x8
Dimensions: (L x W)	48" x 96" (1219 x 1438 mm) / 36" x 96" (914 x 1438 mm)
Thickness	1/2 inch (13 mm)
Tread Depth	.273" (7 mm)- Diamond .149" (4 mm)- Directional Pleat
Hand Holds	8 (two on each side)
Approx Area	32 sq.ft. (2.9 m ²) / 24 sq.ft. (2.2 m ²)
Compressive Strength (5% Strain)	2500 psi (17.2 MPa) @ 74°F (23°C)
Working Load*	120 tons (120,000 kg)
Weight	80 lbs. (36 kg) / 60 lbs. (27 kg)

* Load limits are based on application.

EZG[®] Outrigger Pad

Empowering your teams and equipment with unwavering strength, impeccable load distribution, and ergonomic safety. Our meticulously crafted outrigger pads are expertly designed, utilizing a specially engineered thermoplastic that withstands immense pressure.

Resistant to water and chemicals, these pads are available in four sizes, catering to diverse equipment stabilization requirements. Embrace the assurance of working securely, seamlessly, and economically in the most challenging environments.

Features:

- Sturdy ergonomic design with durable handles for easy 1-2 person carry or roll.
- Safety texture and radius edges and corners.
- Extraordinary power, stability, and longevity facilitate effective distribution of substantial loads.
- Resistant to breakage or splitting caused by prolonged exposure to water, sun or extreme cold.



SPECIFICATIONS	OP36	OP48	OP24-12	OP24-24
Dimensions: (L x W x H)	36" -round (914 mm)	48" -round (1219 mm)	24" x 12" x 2" (610 x 305 x 51 mm)	24" x 24" x 2" (610 x 610 x 51 mm)
Thickness	2 inch (51 mm)	2 inch (51 mm)	2 inch (51 mm)	2 inch (51 mm)
Approx Area	5.24 sq.ft. (0.49m ²)	10.06 sq.ft. (0.94 m ²)	1.58 sq.ft. (0.15 m ²)	3.16 sq.ft. (0.34 m ²)
Compressive Strength*	500 psi	500 psi	500 psi	500 psi
Working Load*	95,000 lbs. (43,091 kg)	120,000 lbs. (54,431 kg)	28,500 lbs. (12,700 kg)	57,000 lbs. (25,855 kg)
Weight	70 lbs. (32 kg)	120 lbs. (54 kg)	20 lbs. (9 kg)	40 lbs. (18 kg)

* maximum allowable pressure / load limit based on application

CUSTOMER REVIEWS

Hog Crusher[®]



Mark Viola, Viola Engineering

“Viola Engineering received our Hog Crusher in January 2015 and have used it routinely to crush concrete test cylinders, asphalt, slab concrete, and rock cobbles to avoid ever increasing disposal cost. An additional benefit is that the Hog Crusher reduces our construction waste to a nominal 2 in. dimension with fines that can be recycled as superior road base and fill material on personal projects. The Hog Crusher is ideal for our intermittent accumulation of construction waste with minimal maintenance. To date, we have processed over 100 tons of construction waste on the same set of carbide bullets without excessive wear.”

Hog Crusher[®]

Model HCR

- Crushes material down to 2" or smaller
- Up to 10 tons per hour discharge rate
- Heavy plate reinforced construction; 1849 lbs (839 kg)
- One-half yard hopper capacity
- 24" wide crushing rotor
- Built-in forklift pockets
- Wear items constructed of abrasion resistant Tri-Braze steel
- Replaceable carbide bits, hardened breaker, cleaner and cheek plates – easy on-site maintenance
- Available with standard or high torque motor
- Designed for brick, block, asphalt, unreinforced concrete and other applications.



[[+](#) [view online](#)]

Krack Hog®

No more shimming wall block to make a clean split. The Krack Hog works with an easily pumped hydraulic foot action pedal, which raises the bottom hardened steel blade. Once the blade meets the stone, it is compressed against the upper blade creating a clean break.

Features:

- 24" (610 mm) wheelbase allows for easy transportation around job sites
- 20 ton / 40,000 psi hydraulic force
- Total Weight: 200 lbs. (91 kg)
- 24" wheelbase for ensured stability and easy mobility
- Splits block from 1 1/2" to 8" thick

**Additional table sizes available*



Krack Hog® Specifications

MODEL	KHBS18	KHBS18-PS
Overall Dimensions: L x W x H in. (mm)	30" x 26" x 41" (762 x 660 x 1041)	30" x 26" x 41" (762 x 660 x 1041)
Table Dimensions: L x W x H in. (mm)	18" x 18" (457 x 457)	18" x 18" (457 x 457)
Pump Dimensions: L x W x H in. (mm)	--	13" x 13" x 9" (330 x 330 x 229)
Power Source	Foot-Action / manual	Cordless Pump / battery
Battery	--	18V/4.0 Ah x 2
Pump Weight	--	12 lbs. (5.5 kg)
Pump Pressure	--	10,000 psi
Wheels	10" (254 mm)	10" (254 mm)
Weight lbs. (kg)	216 lbs. (98)	228 lbs. (103)

Hog Guard®

Hog Guard Scaffold Safety Accessories are engineered to prevent potential fall risks in scaffolding assemblies, blocking openings like door frames or window allowances common in masonry and block jobs. When using Hog Guard components, securely position the uprights in the opening space by hooking onto the walk boards. After placing the end guard and rail assembly, utilize slots at the top, bottom, and middle to insert 2x4s, serving as guard rails and effectively preventing workers from falling through openings.

Features:

- Inter-changeable components are sold separately to custom fit your site needs for added safety.
- Ready-fit design for simple assembly and break down.
- Made to work with most existing scaffold systems.



[view online](#)

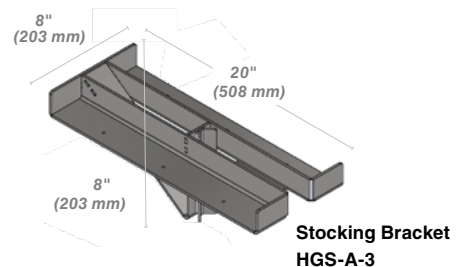
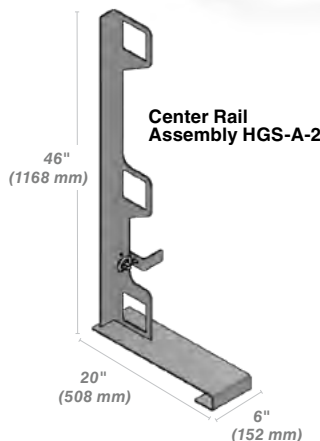
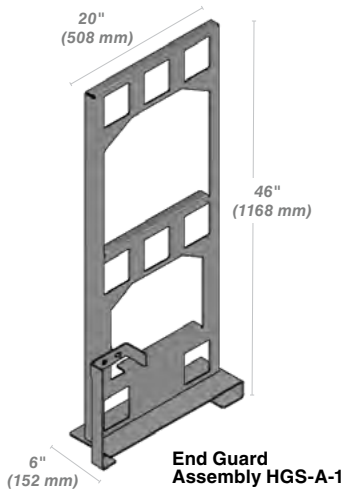

Hog Guard® Component Specifications

MODEL	HGS-A-1	HGS-A-2	HGS-A-3
Overall Dimensions: L x W x H in. (mm)	20" x 6" x 46" (508 x 152 x 1168)	20" x 6" x 46" (508 x 152 x 1168)	20" x 8" x 8" (508 x 203 x 203)
Steel	1/4 in. (base plate) 10 gauge. (vertical)	1/4 in. (base plate) 3/16 in. (vertical)	1/4 in. (base plate) 1/4 in. (vertical)
Weight lbs. (kg)	31 lbs (14)	24 lbs (11)	16 lbs (7)



Hoist Hog®

HHBRS Brick Hoist Hog— Shown With Brick Hog Cart

- Maximum capacity 3250 lb. (1474 kg)
- Empty weight 770 lb. (349 kg)
- Overall dimensions (L x W x H) 63" x 34" x 60"
- Material accessible from one end
- Inside dimensions (L x W x H) 59" x 30" x 50.5"
- Side holders for tubes



[[view online](#)]

HHBLS Block Hoist Hog— Shown With Block Hog Cart

- Maximum capacity 5000 lb. (2268 kg)
- Empty weight 970 lb. (440 kg)
- Overall dimensions (L x W x H) 53.75" x 54" x 58"
- Material accessible from one end
- Inside dimensions (L x W x H) 50" x 50" x 50.5"
- Side holders for tubes



[[view online](#)]

Hog Carts are sold separately; Cart model HC (page 23) is required for the Brick Hoist; Cart model HCBL is optional add-on for the Block Hoist.

CUSTOMER REVIEWS

Booger Hog® ★★★★★

**Jason Allman,
Allman Brothers Masonry Inc.**

"I can't tell you how much time we have saved using the Booger Hog. Walls that might have necessitated a ladder or short rolling scaffolding to do by hand, can be cleaned of mortar splatter with this tool."



Hog Waller®

MODEL - HW3000

- Machine weight 12 lb. (5 kg)
- Extends from 51" to 65"
- 10" guard with built-in vacuum
- 7" abrasive disc
- Vacuum bag with 81" hose
- Comes with carrying case
- LED flashlight provided
- Quicker, easier wall clean-up
- Does the work of 4 to 5 men to save money and time
- Durable and easy to service

[\[+ view online \]](#)



Booger Hog®

Features:

- Machine weight 22 lb. (10 kg)
- 110 V, 5.5 amps, single phase electric power
- 7" diameter diamond grinding disc
- Dust collection head with hose barb
- Overall kit dimensions (L x W x H) 63.5" x 15" x 13"
- Does the work of 4 to 5 laborers to save money and time
- Disc Guard allows better cleaning around corners and door frames
- Includes 5.5A Milwaukee Drill
- Durable and easy to service

[\[+ view online \]](#)



Warranty

EZG Manufacturing (“EZG”) warrants its products to be free of defects in material or workmanship that develop under normal use for two years.



Warranty period begins on the IN-SERVICE date (date of purchase by the end user of the product, date placed in service by a rental operator, or date of any utilization). All warranty is based on the following limited warranty terms and conditions, including the disclaimer of implied warranties and consequential damages. [Warranty registration is required to establish the in-service date and for the warranty to become effective.](#)

EZG Limited Warranty & Limitation of Liability Terms:

1. EZG obligation and liability under this warranty is limited to repairing or replacing parts if, after EZG’s inspection, there is determined to be a defect in material or workmanship. EZG reserves the choice to repair or replace.
2. If EZG chooses to replace the part, it will be at no cost to the customer and will be made available to the EZG Distributor, Dealer, or Rental Center from whom the End User purchased the product.
3. Replacement or repair parts, installed in the product, are warranted only for the remainder of warranty period of the product as though they were the original parts.
4. EZG does not warranty engines. Engine warranty claims should be made directly to an authorized factory service center for the particular engine manufacturer.
5. EZG’s warranty does not cover the normal maintenance of products or its components (such as engine tune-ups and oil & filter changes). The warranty also excludes normal replaceable wear items, i.e. gaskets, wear parts, seals, O-rings, belts, drive chains, clutches, etc. unless such items are deemed to fail due to defective material or workmanship.
6. EZG’s warranty will be void if it is determined that the defect resulted from operator abuse, failure to perform normal maintenance on the product, use of non-manufacturer parts, or failure to follow documented service instructions, alterations or modifications made to the product without the written approval of EZG.
7. EZG will pay shop labor on warranty items at the EZG Shop Labor Rate in existence on the date of the warranty claim. EZG technician will determine the time allowed to complete a repair which will govern the shop labor hours to be allowed.
8. EZG will pay freight on warranty replacement parts at worldwide standard ground rates. No warranty replacement parts will be shipped air freight at the expense of EZG. EZG only pays outbound freight charges when sending warranty replacement parts to the customer via ground service. EZG does not pay any inbound freight. However, if EZG determines this to be a warranted item, EZG will then reimburse the customer for inbound freight at standard ground rates.
9. The EZG WARRANTY POLICY WILL NOT COVER THE FOLLOWING: TAXES; SHOP SUPPLIES; ENVIRONMENTAL SURCHARGES; AIR FREIGHT; TRAVEL TIME; LOSS OF TIME; INCONVENIENCE; LOSS OF RENTAL REVENUE; RENTAL COSTS OF EQUIPMENT USED TO REPLACE THE PRODUCT BEING REPAIRED; LOSS OF USE OF THE PRODUCT; COMMERCIAL LOSS; OR ANY OTHER CHARGES WHATSOEVER OR ANY LIABILITIES FOR DIRECT, INCIDENTAL, OR CONSEQUENTIAL DAMAGE OR DELAY.
10. EZG MANUFACTURING MAKES NO OTHER WARRANTY, EXPRESSED OR IMPLIED. THIS LIMITED WARRANTY IS IN LIEU OF THE WARRANTY OF MERCHANTABILITY AND FITNESS. THERE ARE NO OTHER WARRANTIES THAT EXTEND BEYOND THE DESCRIPTION ON THIS DOCUMENT.
11. No EZG Manufacturing employee or representative is authorized to change this warranty in any way or grant any other warranty unless such change is made in writing and signed by an officer of EZG Manufacturing.

WARRANTY REGISTRATION IS REQUIRED TO ESTABLISH THE IN-SERVICE DATE AND FOR THE WARRANTY TO BE EFFECTIVE.

(some specialty equipment is exempted, or limitations may apply)





1-800-417-9272 | ezgmfg.com | sales@ezgmfg.com

1833 N. Riverview Rd., Malta, OH 43758

EZG Manufacturing is a division of EZ Grout Corporation. All EZG Manufacturing products are backed by our one-year warranty on parts unless otherwise stated and are now available for order. Information in this catalog is subject to change.